

ENGINEERS news

VOL. 62, #8 • OPERATING ENGINEERS LOCAL UNION NO 3 • ALAMEDA, CA • AUGUST 2004



Operating Engineers Local Union No. 3



DEFENDING THE AMERICAN DREAM

Semi-Annual Meeting • Sunday, September 26

11 a.m. Registration • 1 p.m. Meeting

Sacramento Convention Center • Sacramento, California



For The Good & Welfare

By John Bonilla, Business Manager

We can save our transportation dollars

Two years ago, 70 percent of California voters approved Proposition 42, the measure that dedicates state sales tax on gasoline to transportation improvements. We celebrated this as a critical victory for the construction trades.

You've often heard me praise Prop. 42, as it ensures work for our members by earmarking money for transportation projects — a main source of our work. But unfortunately, we haven't been receiving that benefit. You see, there was a loophole in the proposition that voters were not aware of. The loophole allows Prop. 42 to be suspended by the governor and legislature in the event of a fiscal emergency. Consequently, the proposition has been suspended every year since its overwhelming approval.

As a result, during the past three years, more than \$2.2 billion in gas taxes has been used to help bail out the state budget; another \$1.3 billion is pegged for next year's budget; and the California Transportation Commission has \$2 billion in approved projects just waiting to be started.

Our transportation system is suffering because of this loophole — California has the worst traffic and pavement conditions in the nation. For the sake of frustrated drivers throughout the state who battle traffic daily on pothole-filled roads, and for the sake of construction labor, for our livelihood, we must close this loophole.

A group of legislators has already taken an important step in the right direction on this issue. They've created a bill that would prevent the governor and legislature from suspending Prop. 42. With the passage of this bill, if the state encountered a fiscal emergency, the sales tax revenue on gas could be borrowed only on the condition that it would be paid back within the same year or within three years with interest.

This legislation would ensure that Prop. 42 money would be used for transportation, as was intended by the voters two years ago.

We need this legislation; we must make sure it makes it onto the ballot. For this to happen, two-thirds of the legislature must approve it. Local 3 is taking action, and every one of us must encourage our legislators to pass this bill. Our union needs it, our union members need it and our families need it. Write your legislators about the importance of closing the Prop. 42 loophole. Encourage your friends and family to do the same. Together, we can make a difference.

Once we've secured this key legislation a place on the ballot, we will have to get the word out to the voters. We can do this through phone banks, precinct walks or get-out-the-vote campaigns. Whatever we can do, we will do.

Local 3 will need your help. It is with member participation that we make our greatest strides. Prop. 42 is a vital issue for Operating Engineers and the millions of other California workers whose jobs depend on transportation dollars. Let's take action for ourselves and for our union brothers and sisters.

The November election is fast approaching. Look in the coming weeks and months for ways to get involved. With the upcoming local, state and national elections, there will be countless OE CAT activities for which you will be needed; call your district office for information.

Over the next two months, we will publish a list of Local 3-endorsed candidates and positions on ballot propositions in the *Engineers News*, as well as a piece comparing our endorsed candidate, John Kerry, to President Bush. I am certain this will be of use to all Local 3 members.

I look forward to seeing you at our next Semi-Annual meeting at the Sacramento Convention Center Sept. 26. We will have some great guest speakers, and I will update you on the state of our union. Until then, stay safe, and stay involved.



Empire Waste Management Strike. . . . 11

Contents

Flood control	4
Credit Union	6
Fringe Benefits	7
OE CAT	8
Rancho Murieta	10
Inside Negotiations	11
Organizing	11
Semi-Annual	12
Tech News	14
Unit 12	15
Safety	15
District Reports	16
Meetings and Announcements	19
Swap Shop	22
District Reports	23

OPERATING ENGINEERS LOCAL UNION NO. 3

John Bonilla	Business Manager
Bob Miller	President
Frank Herrera	Vice President
Rob Wise	Rec. Corres. Secretary
Harold K. Lewis	Financial Secretary
Russ Burns	Treasurer

ENGINEERS NEWS STAFF

John Bonilla	Editor
Kelly Walker	Managing Editor
Heidi Mills	Associate Editor
Dominique Beilke	Art Director
Duane Beichley	Media Coordinator
Cindy Tuttle	Political & Public Relations Director

FIND US ON THE WEB AT
<http://www.oel3.org>

Engineers News (ISSN 176-560) is published monthly by Local 3 of the International Union of Operating Engineers, AFL-CIO; 1620 South Loop Rd., Alameda, CA 94502. Periodical postage paid at Alameda, CA and additional mailing offices. Engineers News is sent without charge to all members of Operating Engineers Local 3 in good standing. Non-member subscription price is \$6 per year. POSTMASTER: Send address changes to Address Change, 1620 South Loop Rd., Alameda, CA 94502.



Printed on Recycled paper





Talking Points

By Bob Miller, President

In the News

Bonilla re-elected VP of state labor federation

Recently, California Labor Federation, AFL-CIO members from labor unions and councils across the state, including Local 3's delegation, met in San Diego for the federation's 2004 biennial convention. The leaders met to discuss and vote on candidate endorsements for the upcoming November elections and to elect their Executive Council officers.

Local 3's Business Manager John Bonilla, who currently serves as one of the vice presidents of the Executive Council, was re-elected to his position.

Business Manager Bonilla and other leaders from state manufacturing, service, retail, construction, public sector and private industry unions will serve on the Executive Council with Art Pulaski, who was re-elected secretary-treasurer to the Executive Council, and with the federation's newly elected leader and first woman president, Connie Leyva, president of United Food and Commercial Workers Union Local 1428.

Leyva replaces retiring California Labor Federation President Tom Rankin.

The California Labor Federation is the state AFL-CIO, with more than 1,300 affiliated local unions, representing 2.1 million union members in diverse communities and sectors of the state's economy. The federation works to protect and advance the rights and interests of all California workers by supporting:

- **Legislative and political action** – member-to-member information and mobilization on the issues that matter to working families, to elect candidates supportive of working families' issues, and to hold elected officials accountable to working families;
- **Collective bargaining** – negotiating and enforcing contracts to improve wages, benefits and working conditions for workers organizing; and
- **Building power** for working people in workplaces, industries and communities.

In conjunction with the California Labor Federation Convention, the California-Nevada Conference of Operating Engineers held an election of its officers. Congratulations to Local 3 Business Manager John Bonilla, who was elected trustee of the California-Nevada Conference of Operating Engineers.

Uplifting organizing trends

Everyone has heard Business Manager John Bonilla talk about organizing as the lifeblood of our union. He knows that without organizing, Local 3 will eventually die. With organizing success we will continue to grow and prosper and be able to bring the benefits of trade unionism to future generations of Operating Engineers. Your officers and staff remain committed to ensuring a bright future for Local 3 members by making organizing one of our highest priorities.

As part of our commitment to organizing, I was recently looking at national representation election trends and comparing them with Local 3's experience. I was heartened by the national trends and made proud by our election success rate. I'd like to share some of this information with you.

Nationally, the election win rate for unions continued to improve for the seventh consecutive year. In 2003, unions won 57.8 percent of National Labor Relations Board representation elections. This was up from 56.7 percent in 2002 and was the highest win rate in more than 16 years. In fact, unions have won the majority of elections every year since 1996, when the win rate was only 47.7 percent. Local 3's win rate in 2003 was 79 percent — way above the national average. Like you've heard me say before, "when it comes to organizing, Local 3 is second to none."

Overall, the number of elections declined in 2003. But, I'm not sure that's all bad. I think unions are trying to do a better job with their campaigns and, as a result, are emphasizing quality over quantity. Everyone now understands that what counts the most is not how many elections a union has, but how many elections it wins. Following the national trend, in 2003, the number of Local 3 elections also dipped slightly because of our efforts to improve the quality of our campaigns. As a result, compared with previous years, our win rate improved.

Nationally, the IUOE continued to be one of the most active organizing unions. In fact, it ranked fourth among all U.S. international unions. The IUOE was involved in 123 elections, and it had a win rate of 55.3 percent. The IUOE win rate ranked it second among all unions. Local 3 members should be proud in knowing that more than 20 percent of all IUOE elections were the result of Local 3 election activity. And, our win rate of 79 percent was way above the IUOE national average.

I'm optimistic that the positive national organizing trends will continue and Local 3 will maintain its front-runner position in IUOE local union organizing efforts. As the charge officer for organizing, I know we'll make it happen. We've got strong support from Business Manager John Bonilla, Organizing Director Ras Stark, a great bunch of organizers, and most importantly, strong support from Local 3 members.



The flooding created a six-mile diameter lake of farmland that was up to 36 feet deep in some places. About 70 residents and 300 farmworkers were evacuated from the area.

Flood control

Working 24/7, operators repair 500-foot breach in Jones Tract levee

Background photo courtesy of Steve Lopez

Story and photos by Kelly Walker, managing editor



Dragline Operator John Stevens, an eight-year Local 3 member, uses precise timing to maneuver the dragline. With four hand levers and two foot pedals, operating the dragline can be a demanding job.

With determination, teamwork, a strong set of finely tuned skills and state-of-the-art equipment, Operating Engineers Local 3 members helped bring life back to the flooded Jones Tract in Northern California.

Within hours of news of the June 3 levee break near Stockton, Calif., Operating Engineers were on hand to help out. Operating Engineers are often called upon in times of crisis for their ability to get a job done well and fast. This time, the operators were called to repair the levee and reinforce its stability.

Working 24 hours a day, seven days a week since June 5, the operators completed this task about 20 days ahead of schedule on June 30.

Around 8:15 a.m. Thursday, June 3, a fisherman reported seeing “bubbling” water at the levee along the Middle River, a tributary of the San Joaquin River near Upper Jones Tract. What the fisherman saw was a “boil” caused by water seeping under or through the levee, then bubbling up on the other side.

Within 30 minutes, about 65 feet of the levee gave way, and the road that sat atop the levee had washed away. With swiftly flowing water, the break quickly grew to more than 300 feet, and within days had become a nearly 500-foot wide gap.

About 70 residents and 300 farm workers were forced to leave the area per a mandatory evacuation order. The area was not densely populated, as it was mostly farmland — the flood affected more than 11,000 acres of farmland in the Upper Jones Tract and Lower Jones Tract properties, creating a lake about six miles in diameter with a depth of up to 36 feet. Fields of asparagus, tomatoes, corn and wheat were covered in water, causing farmers to lose crops and thus, income.

After trying to save his farm equipment from the rising water, Giovanni Stagi of Stockton told the *San Francisco Chronicle*, “It was like an ocean. I’ve never seen anything like it. I feel bad for farmers. Their paychecks are out in that field.”

Another farmer estimated he lost about \$500,000 worth of crops to the flood. It is predicted that the land may not be ready for agricultural use for two years.

Besides damaging farmland, the breach allowed saltwater into the delta, which is a primary source for the California Aqueduct, forcing authorities to shut down pumps that supply water to about 22 million Californians. Water exports from the delta were cut by 80 percent, and water flow from the Sacramento River was increased to stabilize the freshwater supply.

The flooding forced the shutdown of a high-pressure fuel line that supplies petroleum products to the Port of Stockton; it was also responsible for the deactivation of a PG&E power substation. Damages to the area totaled about \$93 million. It is believed that erosion, burrowing animals and a high delta tide may have caused the break.

The levee breach quickly became a catastrophe, prompting California Gov. Arnold Schwarzenegger to declare a state of emergency in San Joaquin County, which will provide financial relief for the costs of repairing the levee and removing flood water.

Gov. Schwarzenegger then went a step further, and he and U.S. Sen. Barbara Boxer asked President Bush to declare a major disaster in the area. Rep. Richard Pombo and Sen. Diane

Feinstein followed up on the governor’s request by sending a letter to Bush, who responded June 30, officially declaring a major disaster. This means San Joaquin County will be eligible for emergency funds to recover 75 percent of the cleanup and repair or replacement of public facilities.

Having witnessed all of the loss and chaos in Jones Tract, it’s no wonder many of the Operating Engineers have felt a slight sense of heroism through their work in repairing the levee.

“It’s definitely part of the job,” said Captain Dennis Salyers.

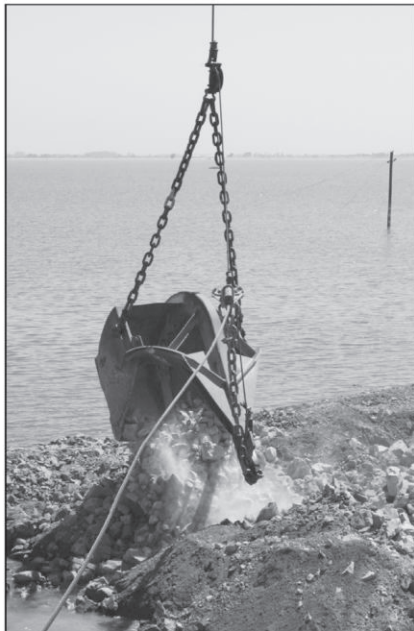

The clam bucket on CB 8 drops a bucket full of rock to bring the levee back up to the proper elevation.



Crane Barge 8 and Derrick Barge 24 are put to work to repair the levee break.

As soon as word got out of the levee break, Dutra Dredging was on hand to help out and got permission to place 4,000 tons of rock to cap the ends so that more of the levee and its road would not wash out. Within two days, Dutra was awarded the contract to repair the levee. To close the breach as quickly and efficiently as possible, Dutra had 40 Operating Engineers working around the clock under the direction of Project Manager Chuck Walker, a 31-year Local 3 member.

Twenty operators were stationed at the breach site. Here, the operators worked on Crane Barge 8 (CB 8) and Derrick Barge 24 (DB 24). Three operators worked per shift on two 12-hour shifts on CB 8, and five operators worked per shift on three eight-hour shifts on DB 24.

Over the course of the 26-day project, CB 8 and DB 24 were used to lift and place more than 200,000 tons of rock to fill the levee break. CB 8 and DB 24 were ideal players for this task. CB 8 has a 120-ton capacity, and DB 24 has a 42,000 pound line pull capacity and can handle a 9 to 12 cubic yard bucket. Crane Barge 1, with a 100-ton capacity, was also on hand in case another crane barge was needed.

Twenty other operators were stationed at Dutra's San Rafael Rock Quarry, which keeps in excess of 50 million tons of aggregate reserves. Operators were on hand at the quarry 24 hours a day, loading 14 barges that shipped rock from the quarry to the breach site all day, every day.

When the barges reached the breach site, operators, using dragline technology on the CB 8 and DB 24, used their clam buckets to scoop the rock and place it in the appropriate location.

CB 8 and DB 24, held in place by spuds, each have a barge winch on deck, which moves the barge so the crane operator can easily reach the rock material.

"We don't have to rely on boats," Salyers said. "We're self-reliant without a bunch of boats around."

A loader was on board to move rock into the clam bucket when the barge with material from the San Rafael Quarry would get low.

Operating the dragline is a full-body experience, just ask eight-year Local 3 member John Stevens, who has been operating the dragline for about five years.

Stevens has four levers to operate by hand and two foot pedals, one for each foot.



Deck Hand John Krenecki, a 10-year Local 3 member, monitors the GPS equipment onboard CB 8.

A round-the-clock team

Project Manager

Chuck Walker, a 31-year Local 3 member

DB 24 Crew

First shift: Dennis Salyers, Daniel Cole, Ernie Hamilton, Rick Heidrich and Ben Silveira. Second and third shifts: Joe Apodaca, Jesse Stubblefield, Jose Garcia, Bill Jenniehan, Craig Haufler, Billy Burch, John Dennison, Delbert Phillips and Keith Beigal.

CB 8 Crew

Days: John Stevens, John Krenecki and Kyle Morse.
Nights: Steve Morse, Nick Schafer and Sam Patterson.



The CB 8 and DB 24 day shifts gather for a picture with Business Rep. Steve Lopez and Dredging Rep. Mark Burton. From left: Business Rep. Steve Lopez, Deck Hand Ben Silveira, Deck Hand John Krenecki, Operator John Stevens, Deck Engineer Kyle Morse, Chief Daniel Cole, Operator Rick Heidrich, Deck Engineer Ernie Hamilton, Captain Dennis Salyers and Dredging Rep. Mark Burton.

"It's all about timing," Stevens said.

The operators used sophisticated GPS technology to tell them the slope of the underwater land they were trying to build back up. Each morning they received a new survey report, detailing the elevations of the ground below. Each day, the operators had to monitor the elevation underwater to make sure they were rebuilding the slope correctly and bringing the levee back to a proper elevation.

The levee was repaired with additional stability measures. The average depth of the floodwater was about 36 feet when the operators began the repair, and they had to bring the elevation back up in five-foot lifts. The levee was built from 220 feet out from the hinge point of the levee. Once the

breach was closed, the operators had to build a slope out from the levee for stability, then lock the levee with "rip rap."

"This acts as a protection so as to not wash away the smaller rock," Walker said.

An average of about 8,000 tons of rock was placed per day.

With the breach closed, the operators now look forward to seeing the floodwater pumped out of Jones Tract and life restored to the area.

Ford Construction, also a signatory employer, was contracted to pump out the water; that work began July 7.

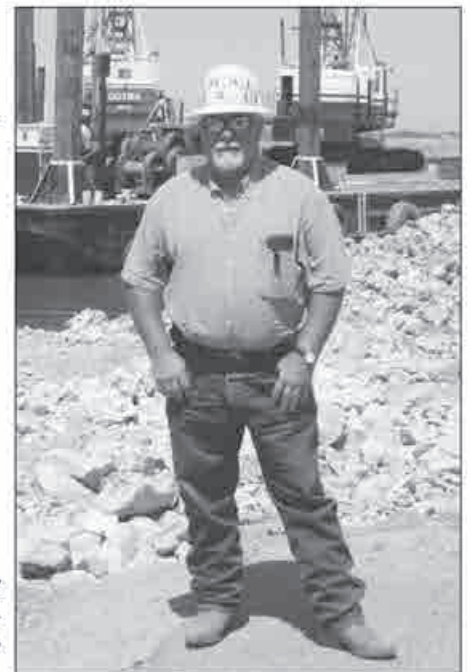

Chuck Walker, a 31-year Local 3 member, serves as the project manager for Dutra Dredging on the levee repair project.



CREDIT UNION

By Rob Wise, Credit Union Financial Officer
& Local 3 Recording - Corresponding Secretary

Earn 3.30 percent APY with a changeable certificate

Has your money been idling in a low-yield account long enough? Then take charge of your money with a Changeable Certificate of Deposit from the Operating Engineers Local 3 Federal Credit Union. Now you don't have to miss out on today's highest rates for fear that rates may go up during the term of your certificate.

How does it work?

Simply open any two-, three- or four-year OEFCU Certificate of Deposit. If rates rise during the term of your certificate, you can choose one time to adjust your rate upward. Annual Percentage Yields (APY) are currently as high as 2.60 percent APY* to 3.30 percent APY*. These rates are exceptional – especially compared to most money market or regular savings accounts. Imagine the peace of mind you'll have knowing these excellent rates can only get better.

**Certificate rate may be increased once per CD at any time during the term of the CD, to the then published OEFCU rate for that certificate term. Penalties for early withdrawals. Deposits not accepted over the duration of the term. APY accurate as of June 1, 2004. Please call (800) 877-4444 for current rates and terms. Balance computation method for computing dividends: Daily Balance. APY stated assumes dividends will remain on deposit until maturity. The rate/APY on this account may change after it is opened.*

A limited time offer

Don't wait to open your worry-free, no-risk Changeable Certificate of Deposit. Take advantage of today's – and tomorrow's – higher rates. Call OEFCU today at (800) 877-4444.

The true meaning of a full-service Loan Center

Did you know credit unions began emerging across the U.S. in the early 1900s? People with common bonds formed their own financial cooperatives to help each other gain sorely needed, low-cost loan alternatives. The credit union movement was based on the working ideal of people helping people.

OEFCU still operates on these principles today; it is owned by its members and gives them the best deals possible on virtually any type of loan. Before

applying for credit of any kind, you should think of your credit union. Unlike merchants, banks or finance companies, your credit union exists solely to serve you – its valued union members.

Not only will you get the best loan selection, rates, terms and service, you'll also enjoy having OEFCU's full-service Loan Center at your fingertips. Visit www.oefcu.org, and take advantage of the comprehensive resources available in the Auto Center and Mortgage Center. For most loan types, you can apply online and receive a loan decision within three minutes. If you prefer to do business in a more traditional style, the staff members of your favorite credit union branch would love to see you in person.

So remember, the next time you're making a major (or minor) purchase and the salesperson asks if you'd like to "save 10 percent today by opening a credit account," tell her you'll save much more by financing with your credit union. Of course, the same thing goes for purchasing autos, homes, RVs, computers, motorcycles and more. Get the best rate, selection, service and value with a credit union loan. Contact OEFCU today at (800) 877-4444, or visit the online loan center at www.oefcu.org.

New headquarters for your credit union

Construction of the new credit union headquarters in Livermore, Calif., began in June 2003 and finished in time for a mid-July move-in. Your dedicated administrative credit union staff is just settling in, and all are enjoying a little more efficiency and elbow room.

Contact information for the new OEFCU headquarters is:

Mailing:
PO Box 5073
Livermore, CA 94551

Street:
250 North Canyons Parkway
Livermore, CA 94551

(925) 454-4000

OEFCU looks forward to serving you from its great new location!

OEFCU branch offices to serve you

CALIFORNIA

Alameda ATM location
1620 South Loop Road
Alameda, CA 94502
(510) 748-7440

Auburn
1915 Grass Valley Hwy., Suite 400
Auburn, CA 95603
(530) 889-2969

Burlingame
828 Mahler Road, Suite A
Burlingame, CA 94010
(650) 697-0598

Dublin ATM location
7300 Amador Plaza Road
Dublin, CA 94568
(925) 560-9660

Eureka
1213 Fifth St.
Eureka, CA 95501
(707) 441-9590

Fairfield
2540 N. Watney Way
Fairfield, CA 94533
(707) 425-4489

Fresno
4860 N. Cedar Ave.
Fresno, CA 93726
(559) 241-0508

Modesto
538 McHenry Ave.
Modesto, CA 95354
(209) 525-8460

Redding
20308 Engineers Lane
Redding, CA 96002
(530) 222-5184

Sacramento
9806 Old Winery Place, Suite 5
Sacramento, CA 95827
(916) 369-6752

Sacramento (Arco Arcata)
4044 N. Freeway Blvd., Suite 150
Sacramento, CA 95834
(916) 565-6190

Sonoma County
6225 State Farm Drive, Suite 102
Rohnert Park, CA 94928
(707) 585-1552

San Jose ATM location
798 N. First St.
San Jose, CA 95112
(408) 995-5095

Stockton
1916 N. Broadway
Stockton, CA 95205
(209) 943-2455

W. Stockton
1818 Grand Canal Blvd., Suite 1
Stockton, CA 95207
(209) 472-0708

Yuba City
468 Century Park Drive, Suite B
Yuba City, CA 95991
(530) 742-5285

HAWAII

Honolulu
1111 Dillingham Blvd., Suite E1B
Honolulu, HI 96817
(808) 841-6396

NEVADA

Reno
1290 Corporate Blvd.
Reno, NV 89502
(775) 856-2727

Elko ATM location
1720 Mountain City Hwy.
Elko, NV 89801
(775) 753-8555

OREGON

Gladstone
805 E. Berkeley St.
Gladstone, OR 97027
(503) 655-5462

UTAH

West Valley City
2196 West 3500 South
Suite C-8
West Valley City, UT 84119
(801) 954-8001





FRINGE BENEFITS

By Charlie Warren, Director

College students covered by California Health & Welfare plan

The Operating Engineers Health & Welfare plan covers unmarried dependent children until age 19. Coverage is extended to age 24 for full-time students enrolled for nine or more units at an accredited school or college. This extension of eligibility applies to participants in Kaiser and the regular plans.

Students can maintain their student status during the summer months if they are enrolled for the terms preceding and following the summer break. Students age 19 and older are required to submit proof of enrollment from the school registrar's office each semester or quarter. Failure to submit this documentation will result in a delayed claim payment.

To ensure smooth coverage, the Trust Fund office offers the following tips:

At the beginning of each semester or quarter, submit a completed Student Dependent Certification form to the Trust Fund office. This form

should be available from your district office, the Fringe Benefits office or the Trust Fund office. Upon receipt, the Trust Fund will note the information, and any claims submitted can be processed normally.

The student should make a copy of the certification for his or her records.

When requested, students covered under the Kaiser plan should submit proof of enrollment. This is in addition to providing the required documentation to the Trust Fund office.

Take care to ensure all correspondence is properly identified. Trust Fund records for dependents are filed under the member's name and Social Security number. The Trust Fund office reports that students and schools often send the certifications without identifying information such as member's name and Social Security number. In many cases, the Trust Fund cannot match these forms to the proper member.

Fifteen reasons to exercise daily

1. It reduces your risk of dying prematurely.
2. It reduces your chances of developing heart disease.
3. It reduces your risk of stroke.
4. It reduces your risk of developing high blood pressure and improves HDL "good cholesterol" levels.
5. It lowers blood pressure if you have high blood pressure.
6. It helps prevent or control diabetes.
7. It improves your mood and self-image.
8. It combats depression and anxiety.
9. It reduces your risk of colon cancer, breast cancer and possibly other cancers.
10. It burns calories and helps control weight.
11. It strengthens muscles, bones, and joints and helps prevent osteoporosis.
12. It keeps seniors stronger and reduces the risk of falling.
13. It decreases the chances of developing impotence.
14. It reduces pain from arthritis.
15. You meet other active, health-conscious people.



Time to quit smoking? Six reasons to consider quitting

1. Tobacco use causes deadly diseases, including lung cancer, heart disease, emphysema and stroke.
2. Tobacco use causes impotence.
3. Tobacco use makes your job more dangerous. Tobacco smoke damages your lungs so they're more easily hurt by other hazardous substances you're exposed to on the job. When construction workers are exposed to toxic hazards on the job such as silica, formaldehyde, benzene and lead, they know to take special precautions, like wearing respirators, gloves and wetting down surfaces. Cigarettes contain many of the same toxic substances, but there are no precautions the smoker can take.
4. Shorter retirement. The average smoker dies seven years earlier than s/he would if s/he never smoked. Heavy smokers can begin to get seriously ill in their 50s or even younger. Those hard-earned retirement years can't be enjoyed if you are suffering from tobacco-related illnesses.
5. All members' benefits are affected by smoking. More money can go into wages and pensions if it doesn't have to be used for health care costs for tobacco-related illness. When Health and Welfare Trust Funds pay out on large claims, this is a direct cost to every member who participates in the fund.
6. Less money in your pocket. Smoking is expensive. Buying just one pack of cigarettes a day for a year costs more than \$1,000.

If you smoke and work with toxic chemicals, your health risks are greatly increased. For example: your risk of lung cancer is increased 11 times; if you work with asbestos, your risk is increased 50 times.

If you're ready to quit, free and confidential telephone counseling is available to California residents at (800) NO-BUTTS; that's (800) 662-8887.

What's in your cigarette?

Butane – Highly flammable; a component of gasoline.

Acetone – One of the active ingredients in nail polish remover.

Ammonia – Helps you absorb more nicotine, keeping you hooked on smoking.

Cadmium – Found in batteries. Damages liver, kidneys and brain. Stays in body for years.

Lead – Damages brain, nerves, kidneys and reproductive system; causes anemia and stomach problems.

Phenol – Used in disinfectants. Weakens your lungs.

Benzene – Found in pesticides and gasoline. Causes leukemia.

Hydrogen cyanide – Used in the gas chamber. Weakens your lungs.

Propylene glycol – Found in de-icer.

Toluene – Highly toxic. Used in paint thinner.

Benzopyrene – One of the most potent cancer-causing chemicals.

Arsenic – A deadly poison. Makes your lips burn, your breath turn bad.

Formaldehyde – Embalming fluid. Causes cancer; damages lungs, skin and digestive system.



OE CAT

By Cindy Tuttle, Political Director

Thank you, Volunteers of the Year

It is my pleasure to announce Local 3's outstanding Volunteers of the Year for the 2003-2004 CAT season. These dedicated men and women went above and beyond their duties as union members, spending time after work and on weekends promoting the interests of the membership. They are proud, committed, motivated and hardworking. It is members like our Volunteers of the Year who play an instrumental role in keeping this great union strong. On behalf of Business Manager John Bonilla and the Local 3 officer team, I want to thank all of our CAT activists and captains for their hard work and dedication to Local 3 and offer a special thank you to the following members who were chosen by their districts as Volunteers of the Year.

District 01/02/03 – San Francisco

The San Francisco District Volunteers of the Year are Patty Oku and Jeff Pearson.

Patty Oku is an elevator operator in San Francisco. She grew up in a union household and remembers walking picket lines with her father as a child. She believes "in the power of activism."

Jeff Pearson is a crane operator and 23-year Local 3 member. When asked why he volunteers, Jeff replied, "to help get work for Local 3 members."



Patty Oku



Jeff Pearson

District 04 – Fairfield

The Fairfield District is proud to have two volunteers qualify for this award: Noble "Buzz" Johnson and Christopher Miller.

The Fairfield District office thanks Noble "Buzz" Johnson for the help and support he offered Local 3 this past year. He joined Local 3 in July 1979.

Buzz can be counted on for help without question anytime. He donated time phone banking for the past election and attended every district meeting. He attended a school board meeting in Fairfield regarding a project labor agreement and was one of the last people to leave. Buzz also put in time holding picket signs with us at the Valero Refinery in support of our brothers at Kinder Morgan.

When we told Buzz he was one of District 04's CAT Volunteers of the Year, he

said he didn't do these things to get awards, but because it's what Local 3 needed him to do. He said he is glad to help.

The Fairfield District thanks and applauds Christopher Miller, who has been a CAT captain for two years. He put in more than 40 hours phone banking and precinct walking this last CAT year. Chris' dedication and enthusiasm are an example of how to give back to our union. Chris said he's active because he realizes this really is OUR union.

Chris is not only an asset to the CAT but in the apprenticeship program as well. He's currently a fourth-period apprentice and a graduate of the International Union of Operating Engineers Job Corps Training Program.

We are very proud of his hours served. The Fairfield staff recognizes and truly appreciates Chris' hard work.



Christopher Miller



Nancy Fagerness

District 10 – Rohnert Park

Nancy Fagerness has been unflagging in her support of our district's CAT. She is not only our most dependable volunteer, but she does it all at a time when, as a retiree's wife, most members are taking it easy.

District 11 – Nevada

Brian Prather, a seven-year Local 3 member, is a star on the District 11 CAT. He participates in all of our CAT activities and last year volunteered more than 200 hours at the apprenticeship site. On his own time, Brian goes to the site (which is 30 miles outside town) and works with apprentices and journey-level operators. He trains others on a

variety of equipment and teaches gradesetting.

"Brian Prather is a great role model for our apprentices and journey-level operators," District Rep. Chuck Billings said. "Sharing your expertise with others and working to improve the community are definitely the kind of qualities that we want to honor in a member."

Brian graduated from the apprenticeship program in 2000 and was honored as Apprentice of the Year. He is currently employed by Q&D Construction as a gradesetter.



Brian Prather

District 12 – Utah

District 12's Volunteer of the Year is Richard Brewster, a seven-year Local 3 member. Richard has been an active member from the start of his union career. Not only is he a job steward at Kennecott Copper, he is a member captain on the CAT and very active politically. He is always available for anything from meetings in the hall to picket duty, as seen in the above picture taken in Denver, Colo.



Richard Brewster

District 17 – Hawaii

Sean Amaral is an asset to District 17's CAT. He is a leader and has volunteered many hours to CAT functions. Whether it is a community or political function, Sean has always made himself available. We would like to acknowledge him for the time he has given to Operating Engineers Local 3.



Sean Amaral



Buzz Johnson

District 20 – Oakland

The Oakland District is proud to have two volunteers qualify for this prestigious award. Our Volunteers of the Year are Patrick Farley and Steven Harvey.

Patrick Farley is a family man with three sons; he is dedicated to his family and Local 3. A crane operator, Patrick is a 16-year member and has served as a Local 3 job steward for eight of those years.

When asked why he volunteers, Patrick said, "A member of Local 3 should not sit on the sidelines. We are Local 3 and that means we have a duty to our family and ourselves to participate. I try not to let the other fellas do all the work. We have to get involved if we are to survive. Besides, a few hours out of a year is no big deal when you can see the results of what you accomplished by donating your time."

Steven Harvey is a family man with one six-year-old boy and a 16-year-old girl. Steven is a first-step crane apprentice currently working for Manson Construction.

Steven was asked why he volunteers for the CAT. His response: "I want to be involved with what Local 3 stands for." He also said he recognizes the need for everyone's political activity, and by helping Local 3, he is helping his family. That is what it is all about.



Patrick Farley

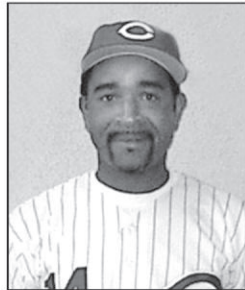

Steven Harvey

District 30 – Stockton

The Stockton District CAT Volunteer of the Year for 2003-2004 is Bart Marquez. Bart is an 18-year member who has become an invaluable asset to our CAT and an integral part of our union family in the Stockton District. Without Bart's commitment to the cause, we would not have achieved the level of success we did. The membership and staff of the Stockton District owe Bart a debt of gratitude worth more than words can say.



Bart Marquez

District 40 – Eureka

District 40's CAT Volunteer of the Year is longtime member Don Allen. Don was initiated into Local 3 in 1955 and has since given a great deal of time to the local. He donated all of the money he earned teaching gradesetting classes to the local's Political Action Committee. This year he spent time promoting the Operating Engineers at the Redwood Acres Fairgrounds.



Don Allen

Don and his wife, Gloria, attended the first crab feed in the Eureka District and have not missed many since. Don and Gloria support Local 3's endorsed political candidates by attending as many meetings and events as they can.

District 50 – Fresno

Ronald "Gus" McClain has been a member of Operating Engineers Local 3 for 18 years. He has worked mostly in the Fresno area, currently as a crane operator for EL Yeager on the Hwy. 180 project. This year, Gus went beyond the call of duty in his volunteer capacity. He attended almost every district event and gave 110 percent to his union. In addition to serving on the Fresno District Grievance Committee, he is our "Smooth Operators" Fresno District co-ed softball team coach. Our (hard) hats are off to you, Gus! Thank you.



Gus McClain

District 60 – Yuba City

For the second consecutive year, Alex Bryce is the District 60 CAT Volunteer of the Year. This is a well-deserved honor for Alex. Not only has he contributed more volunteer hours than any other member in our district, he is always prepared to volunteer for his union at a moment's notice. He has never let us down. Alex is a great asset to Local 3 and District 60. Thank you, Alex!



Alex Bryce

District 70 – Redding

District 70's CAT Volunteer of the Year is Jeremiah Atkinson. Jeremiah is a second-step apprentice who was initiated into Operating Engineers Local 3 in 2002. Jeremiah works on the dirt crew for Tullis of Redding, Calif. When asked why he believes it is so important to be involved, Jeremiah said he wants to give back to Operating Engineers Local 3 for a great job and the benefits he receives. He said through member involvement, we keep Operating Engineers Local 3 the leader it has always been.

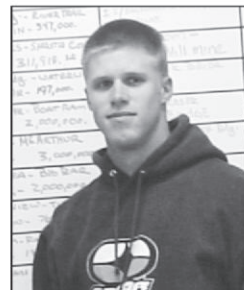

Jeremiah Atkinson

District 80 – Sacramento

Jane Lea is always a willing volunteer whenever the occasion arises, and that is why she was nominated as one of our top volunteers, along with Felicia Ramos. As an instructor at Job Corps, Jane brings volunteers down to help out in district activities. She is very friendly, and we enjoy having her as a member and active participant in the CAT.

Felicia Ramos is one of our top volunteers for phone banking and precinct walking in District 80. On top of her volunteer work, she always brings her daughters to help us out. Felicia has a great personality and is always willing to help her union.



Jane Lea



Felicia Ramos

District 90 – San Jose

The San Jose District is proud of all its volunteers and selected Larry Watson and Douglas Zachary as our Volunteers of the Year. Even though Larry and Doug are new to the union, both are enthusiastic and vocal supporters of Local 3. They have been active participants in numerous precinct walks and phone banking sessions and are willing to go the extra mile to get things done. They logged numerous hours since the inception of the CAT and have been instrumental in the growth and strength of the program in the San Jose District. Larry and Doug are currently serving on the District 90 Market and Geographic Committee and understand how vital various committees and programs are to the strength and future of Local 3. They encourage all members to volunteer and become proactive participants.



Larry Watson



Douglas Zachary



RANCHO MURIETA TRAINING CENTER

for Apprentice to
Journey-level Operators

By Curtis Brooks, Director

Personal rights are not a thing of the past

The time has come for us to pay attention to how we address each other. Harassment in any form affects the bottom line no matter your place of business. Our signatory employers and employer associations agree these types of issues have no place on the construction site. The old way of doing things may have been tolerated for the most part, but it never left anyone feeling respected or needed and should never have been a part of training. Today we address this issue because respect and common decency are not a thing of the past, nor are basic rights.

Part of the problem is, for some, there isn't an easy way to separate who we are as people from who we are as workers just because we're on the jobsite. For some, words and gestures have no meaning, but for others, they are interpreted as hostile and offensive. As union members, we should know better than anyone what it is like to have our rights infringed upon. As organized workers, we have had a long history of crusading for the workers' cause. Today, we not only strive to be the best in training but also in employment, which is a direct benefit to our signatory employers. We will not only be able to do the job on time and under budget, but also harassment free.

A portion of the JAC harassment/sexual harassment policy is printed below.

The purpose of this Policy Statement is to inform all employees, contractors, vendors, agents and consultants, the Local Union, journeymen, instructors and apprentices that the Operating Engineers Joint Apprenticeship Committee (JAC) has a policy prohibiting harassment and discrimination based on race, color, religion, sex, national origin, age, handicapping condition, marital status, or political affiliation in the workplace and in the classroom.

Sexual harassment has been defined by Federal and State law as a form of sex discrimination. Sexual harassment is defined by the Equal Employment Opportunity Commission Guidelines as "unwelcome sexual advances, requests for sexual favors, other verbal or physical conduct of a sexual nature," when:

1. Submission to such conduct is made either explicitly or implicitly a term or condition of employment [including hiring, compensation, promotion or retention] or advancement through an apprenticeship program;
2. Submission to or rejection of such conduct by an individual is used as a basis for employment or school decisions affecting such individual; or,
3. Such conduct has the purpose or effect of unreasonably interfering with an individual's work or school performance or creating an intimidating, hostile, or offensive work or educational environment.

Any violation of this policy by an employee of the JAC shall constitute grounds for discipline up to and including immediate discharge.

A non-employee who subjects an employee, apprentice, or trainee to harassment/sexual harassment in the workplace or the school will be informed of the JAC's harassment policy and appropriate action, within the authority of the JAC to take, will be taken.

An employee or student who feels that he or she has been sexually harassed as defined above is strongly encouraged to immediately bring the subject to the attention of his or her immediate supervisor or, in the case of an apprentice, to the immediate attention of the Apprenticeship Coordinator. If an employee believes that he or she has been harassed as defined above by his or her immediate supervisor, he or she should immediately bring this matter directly to the attention of the Director.



Mechanics Corner

By David DeWilde



Moving on with computers 101

In our last article we covered And, Nand, Or and Nor gates. These are simple devices that make a pre-determined logical decision, the same one every time. We also learned about 1s and 0s.

Most of us have heard the term "computer chip." Another, maybe more proper term is a IC (integrated circuit).

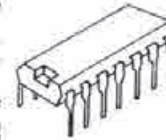

Figure 1

Figure 1 is an example of a chip in its housing. The chip itself is very small, so manufacturers encase the chip in a housing and connect wires internally to the legs that you see. Figures 2 and 3 illustrate a schematic view of its internal components. Recognize them? Yes, they're Nand and Nor gates, four in each chip. Figure 2 is a Quad Nand Gate. Figure 3 is a Quad Nor Gate.

Notice the notch on the left side of the chip. This indicator determines where the No. 1 pin is. Pin 14 is power and Pin 7 is ground. You turn this chip on by supplying power (3 to 5 volts) and ground to it.

Many systems use the output of one chip to turn on another chip. Usually chips are grounded to the printed circuit board's ground. Sometimes the inputs and outputs of several chips are connected to a set of common wires called a data bus. Which chip is turned on at that time determines what type of logic decision is being performed.

These are examples of basic chips. They can become very complex and contain hundreds or thousands of components. Switch these chips on and off, read information, add a few 1s and 0s at a rate of 3 billion times per second and voila. Computers seem smart – not really, but they are fast.

I've simplified the internal workings of computers for explanation purposes to show you they are mechanical (or electromechanical) in their actions and with training, all of us can use them.

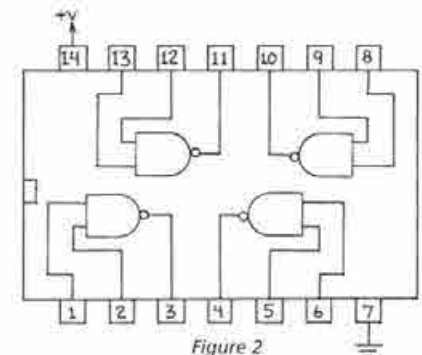

Figure 2

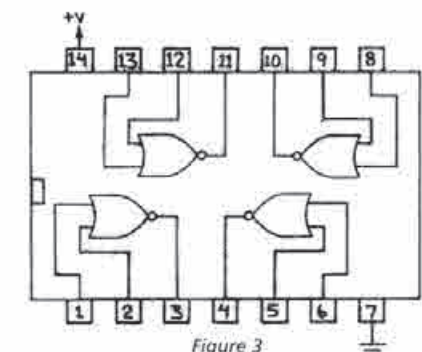

Figure 3

CCO Tests for new candidates

2004 Written Exam

Exam date	Application deadline
Oct. 24	Sept. 3
Dec. 19	Oct. 29

CCO Practical Test

New CCO candidates and candidates who have passed the written portion of the CCO exams should contact Theresa Brooks at (916) 354-2029, extension 232, to schedule an appointment or obtain CCO information on the Practical Test dates.

APPRENTICESHIP GRADUATES

Carlos Luera	Construction Equipment Operator	San Jose	June 7
Guy Guibor	Crane Operator	Stockton	June 7
John Young	Construction Equipment Operator	Fresno	June 14
Juan Ruelas	Construction Equipment Operator	San Jose	May 31
Keith Silva	Heavy Duty Repairer	Sacramento	June 7
Sean Cox	Construction Equipment Operator	Yuba City	June 21
Tim Barton	Construction Equipment Operator	Sacramento	June 21



INSIDE NEGOTIATIONS

By Frank Herrera, Vice President

Negotiating in solidarity

This summer has been one of the busiest for Local 3 in terms of contract negotiations. In the months of June and July, negotiating committees across our jurisdiction spent an enormous amount of time at the table.

The fact that we are spending so many hours in negotiations is noteworthy. We're meeting with new contractors, signing first-time contracts and working hard on contract renewals. What's more, Local 3 is now enjoying the benefits of negotiating in cooperation with the other trade unions in our industry.

Business Manager John Bonilla's involvement in the creation of the Basic Craft Alliance with the Operating Engineers, Carpenters and Laborers has opened doors for unions in the industry that never before existed, let alone were accessible. Together, unions are improving the management of jurisdictions on our jobsites, creating a stronger presence in the political arena and establishing greater leverage in contract negotiations.

The Alliance has helped identify Local 3 as an innovative union, one that is taking a bold new approach to benefit its members and signatory employers. Under the guidance of Bonilla, the Alliance most recently helped create a similar union alliance in the rock, sand and gravel industry, involving the Operating Engineers, Teamsters, Laborers and Machinists, called the Rock Solid Union. Like the Basic Craft Alliance, the Rock Solid Union has trade unions hooked at the hip.

The first task of the Rock Solid Union is negotiations on a contract renewal with Graniterock at the Wilson Quarry in California's San Benito County. The Wilson Quarry contract expired July 15 and has a direct effect on 45 Operating Engineers and many other members from the Teamsters, Laborers and Machinists unions.

The Rock Solid Union has been working on this renewal since the beginning of May, and while we've made progress on a number of important issues, several others remain on the table.

Issue No. 1: wages and fringe benefits. With this contract renewal, like all of our other renewals and first-time contracts, wages and benefits are top

priorities. I am pushing for increases and extras in this area for the membership and will continue to push forward until the majority of our members are satisfied. Operating Engineers remain united with the Teamsters, Laborers and Machinists on the issue of wages and benefits, just as we do on the second major sticking point in the Graniterock contract, strike language.

Graniterock representatives are insisting on strike language that contradicts the strike language Local 3 has in its agreements with other union employers. In fact, the company's strike language contradicts federal law – it takes away workers' right to strike as outlined in the National Labor Relations Act.

The Rock Solid Union wants nothing above or beyond the law regarding strike language in this contract, and we are committed to holding our ground on this issue.

The last major continuing issue with Graniterock has to do with the fact that the contract is a multi-union agreement. Graniterock is pushing for intercraft transfer, which means all four crafts on the jobsite are expected to perform their work as well as the work of their co-workers from other trades. In other words, the Laborers must be able to do the specialized work of Operating Engineers, who must perform the Laborers' job. The unions are opposed to such changes.

Intercraft transfer goes against everything the Rock Solid Union stands for. Each union in the alliance represents skilled, specialized craftsmen – we do not and will not perform each other's work.

The Rock Solid Union has aligned itself to maintain solidarity and collectively confront intercraft transfer and each of the other major issues on the table. It is important for us to stand united with our union brothers and sisters in dealing with a company like Graniterock that chooses to oppose industry standards. Local 3 has good working relationships with other employers in the industry, and we will continue to achieve fair and equitable agreements with each of them. We refuse to allow one company to take our industry down.

In solidarity.



ORGANIZING

By Ras Stark, Organizing Director

Second time around



Organizing Asst. Director Todd Doser and Organizer H.K. Pang stand on strike with Empire Waste Management workers during recent negotiations. Local 3 did not win the representation election the first time, but returned to win it the second time around.

Some people say that experience is the best way to learn, and as many have observed, it's usually the most expensive. I was again reminded of this saying while reviewing several current Local 3 organizing campaigns. We are organizing in a number of units where we previously experienced election defeats. We have returned to these units because workers there asked us to come back and help them try again to get the benefits of union representation. In several instances, the call came from workers who told us they voted against union representation in the first election. They told us they now realize they made a big mistake in granting their employers' request to be given a "second chance" to improve their wages and working conditions. A year or two had passed, and things hadn't gotten any better.

This got me thinking about what a tremendous personal price many of the workers paid because of their error in judgment. Firings and harassment, no raises, no health care benefits and in some cases, huge health care premium co-pay increases. For some of these workers, the co-pay increases were so large they could no longer afford to pay it, leaving them and their families without insurance. Like I said, these workers paid a tremendous price for believing their employers' false promises. For them, it was indeed a learning experience, a very expensive learning experience. Because of this, I'm confident we'll have a positive outcome in our upcoming representation elections.

As I thought about this situation, it occurred to me that Local 3 also learned an important lesson from this. The lesson is that losing an election isn't always a bad thing. It doesn't always mean that all is lost. Especially when we lose an election by only the narrowest margin. Many workers who originally voted for union representation now know they must do more to gain the support of their co-workers to get a victory. Workers who voted against representation experienced their employers' broken promises and are mad about being deceived. They are now ready to join their co-workers and work hard to get the protection and benefits of a union contract. What we couldn't get done the first time, we can now get done the second time around!

As we enter our peak work season, I would like to thank Business Manager John Bonilla, President Bob Miller (our charge officer for organizing) and the other Local 3 officers for their ongoing support of our organizing efforts. I'd also like to thank the many members who have actively supported our organizing by calling in organizing leads, working as "salts" in the off season and helping to spread the word as to why organizing is so important to ensuring Local 3 will be as strong in the future as it is today. You're the best! Keep up the good work!



DEFENDING THE AMERICAN DREAM

Local 3: Defending the American Dream at the Sept. 26 Semi-Annual in Sacramento

Business Manager John Bonilla is pleased to invite all Local 3 members and their families to the union's next Semi-Annual meeting, Sunday, Sept. 26, at the Sacramento Convention Center. The meeting begins at 1 p.m. in Exhibit Hall B of the convention center with registration at 10 a.m. Brown-bag lunches and beverages will be available after registration at no cost to the membership.

Invited guest speakers include Democratic presidential candidate John Kerry and retired California Sen. Art Torres. Local 3 Business Manager John Bonilla, in his state-of-the-union address, will update the membership on the union's work picture and efforts in training, organizing and politics.

Members and guests are encouraged to arrive early and stay after the meeting to visit informational display booths from various Local 3 departments, view the equipment display and take advantage of free health screenings provided by Local 3's Health Care Division.

Members from Utah or Hawaii who are unable to attend the meeting in Sacramento but would like to be a part of the event can watch it via video broadcast at select locations at 1 p.m. Pacific Standard Time. Contact your district hall for more details. Anyone who attends the Semi-Annual in Sacramento or long distance and is a dues-paying member is eligible for gift certificates donated to the local for the raffle drawing.

United in our defense

This Semi-Annual, we come together to unite around one cause. We come together in defense of the American Dream.

A simple but powerful concept, the American Dream is the idea that if you work hard, you will earn enough to house and feed your family, provide for your children's health and education and retire with security and dignity. It is what generations of courageous unionists have worked to make available to working men and women in this country for more than a century.

Today we must defend the American Dream because it is under attack. For the past four years, we have witnessed the Bush administration and the conservative leadership in Congress work in cooperation with corporate special interests and against working families on issues important to us, such as health benefits, retirement security, and the right to organize and bargain. Ironically, their fiercest attack has been on the one issue that truly affects our lives and our future: jobs.

U.S. jobs that pay well have disappeared as a result of the Bush administration's failed economic policies based on tax cuts for millionaires, laws that encourage companies to move jobs overseas, and the unwillingness of Bush and Congress to embrace

job-creating programs to repair the schools, and rail and water systems

Local 3 has been fighting Bush's worker agenda since the day he took office in 2001. Through our aggressive efforts, labor coalitions and OE CAs we will continue the fight to protect Operating Engineers across our jurisdiction as long as it remains necessary to do so. There is no American Dream without America.

It is up to us to sound the alarm and mobilize our union in defense of the American Dream this election season. We have the opportunity on Nov. 2 to cast a vote for a leader who is not only pro-jobs, but also pro-worker, pro-PLA, pro-organizing, pro-wage, pro-health care reform and pro-civil rights. With this in mind, let's call on our union members and worker activists to stand in defending the American Dream.

Directions to the Sacramento Convention Center

From San Francisco / Oakland

Take I-80 East
 In Sacramento follow Business I-80
 Take I-5 North
 Take J Street exit
 Convention Center is on J Street between 13th and 14th streets.

From Reno

Take I-80 West
 In Sacramento follow I-80 West/San Francisco
 Take I-5 South
 Take J Street exit
 Convention Center is on J Street between 13th and 14th streets.

From Redding

Take I-5 South
 In Sacramento take J Street exit
 Convention Center is on J Street between 13th and 14th streets.

From Fresno / Stockton

Take I-5 North
 In Sacramento take J Street exit
 Convention Center is on J Street between 13th and 14th streets.

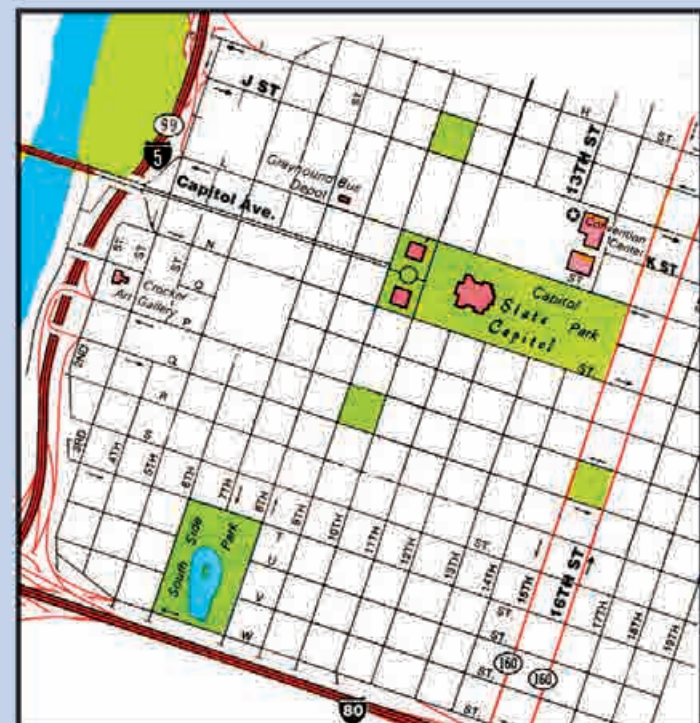

Once on J Street, follow signs with the Local 3 logo to parking.

e nation's roads,

s anti-job, anti-
 was sworn into
 ressive lobbying
 T mobilizations,
 protect jobs for
 jurisdiction for as
 o, because there
 erican jobs.

ake-up call and
 f the American
 e a great oppor-
 a new American
 also pro-union,
 g, pro-prevailing
 and pro-workers'
 me together as
 sts and succeed



TECH NEWS

By Business Representatives Ed Wodzienski and Rob Jones
and Testing, Inspection and Surveying Director Dean Dye

Working with post-tensioned concrete

Because post-tensioned concrete is normally constructed on site rather than fabricated in plants, more responsibility is placed on the independent inspection agency to verify that quality control meets acceptable standards.

This objective can best be achieved by qualified special inspectors performing the following duties under the direct supervision of the materials engineering laboratory.

Observational duties

A. Documents

1. Review the approved plans, specifications, and approved placing and stressing drawings furnished by the post-tensioning contractor.
2. Review the reinforcing steel placing drawings to check whether they have been coordinated with the stressing drawings.

B. Mill test reports

1. Check that reinforcing steel and post-tensioning steel supplied to the job are properly identified and mill test reports show conformance to project specifications.

C. Sampling

1. Sample and deliver the following materials to the laboratory for testing when required by project specifications:
 - a) Concrete aggregates and cement
 - b) Prestressing strand, rods or wire
 - c) Reinforcing steel
 - d) Steel used for structural inserts

D. Steel fabrication of embedded items

1. Visit fabrication plant.
2. Verify that qualified welders only are welding in accordance with AWS Structural Welding Code.
3. Verify that only qualified welding procedures are being used.
4. Observe the welding operations and the finished product for defects and verify that corrections are made, if necessary.

E. Pre-placement observations

1. Check the general layout, size, spacing and profile of reinforcing steel and post-tensioning steel.
2. Observe anchorages, inserts, embedded items, block outs, conduits, etc.
3. Calibrate or review current calibration data on the proposed stressing equipment.

F. Observation during concrete placement

1. Observe batch plant operations when required.
2. Observe concrete placement and report any damage or misalignment of embedded components (with particular emphasis on end anchorages).
3. Cast compression test specimens.
4. Test slump, air content and unit weight. Request adjustment as necessary.

G. Stressing

1. Verify that the concrete compressive strength meets the minimum required strength before post-tensioning.
2. Check the stressing sequence and verify the required post-tensioning forces.
3. Call to the attention of the structural engineer any out of tolerance discrepancy in force-elongation relationship, spalled concrete, broken tendons or anchorage slippage.
4. Verify friction losses where applicable.
5. When using bonded tendons, observe grouting procedure.

H. Reports

1. Submit written progress reports describing the tests and observations made and showing the action taken to correct nonconforming work. Itemize any changes authorized by architect/engineer. Report all uncorrected deviations from plans or specifications.



Welding techs

Testing, Inspection and Surveying Director Dean Dye (third from left) stands with Susan Chae-Bell, Ramsey Bell and David Cox of Critical Welding Inspections, a firm based in San Francisco that specializes in the inspection of non-destructive testing of welds.



MISSION STATEMENT

At Operating Engineers Local Union No. 3, our mission is to build and maintain an organization that provides the best possible member service by:

- Providing quality jobs through organizing and political activism
- Negotiating the best possible wages, fringe benefits, and working conditions
- Providing journey and apprentice level training that is second to none



UNIT 12 STATE CRAFT AND MAINTENANCE

By Flo Davis, Unit 12 Director

It's nice to win one!

We have all heard this saying, and so true it is!

I am pleased to share with you that Local 3 recently not only won a State Personnel Board (SPB) hearing, but the decision created a new precedent in the area of non-punitive terminations.

Government Code section 19585 allows for the termination, demotion or transfer of an employee who fails to meet a requirement for continuing employment. Such a non-punitive action is considered non-disciplinary.

In *Skelly v. State Personnel Board*, the California Supreme Court articulated the procedural due process requirements that an appointing power must meet before depriving a state civil service employee of his or her job. Those requirements include notice of the proposed action and the reasons therefore; a copy of the charges and materials upon which the action is based; and the right to respond, either orally or in writing, to the authority initially imposing the discipline. These Skelly rights apply to both disciplinary actions and non-punitive terminations.

In this case, the appellant received a notice of non-punitive termination after his Class B driver's license was suspended. However, the department failed to afford the appellant his Skelly rights before the effective date of the action.

The appellant requested the opportunity to respond to the appointing power within the appropriate time frame, before the effective date of the action.

The department upheld the termination with its original effective date, even though the due process rights of the appellant were not satisfied until the Skelly hearing was held about five weeks after the effective date of the action.

When the Skelly hearing was held, the appellant had regained his Class B driver's license and met all of the requirements for continuing employment. Because he met all requirements as of the date the action should have been effective (the date of the Skelly hearing), the department could not separate him under Government Code section 19585.

Because of the Skelly violation, the conditions for non-punitive termination were no longer valid as of the date of the Skelly hearing, which was the appropriate effective date of the termination. The non-punitive termination was revoked.

As a result, the appellant is entitled to reinstatement, all back pay and benefits, if any, that he would have accrued had he not been unlawfully taken off the payroll, plus interest at the rate of 7 percent per year.

It is nice to win one!



SAFETY

Michael Dunlap, Safety Director

Speaking of safety

The following schedule of refresher and 40-hour classes is the Hazmat training schedule for fourth quarter 2004 and first quarter 2005.

Those interested in eight-hour refresher classes may sign up in the district office. There is no cost to members. Non-member cost is \$50, and payments should be made to the OE3 JAC. The class size should be a minimum of 15 students.

Anyone wishing to take the 40-hour Hazmat class needs to sign up with me, Mike Dunlap. I can be reached at (510) 748-7400. There is no cost to members who are unemployed and on the out-of-work list. The fee for employer-sponsored members or non-members is \$400 and should be paid to OE3 JAC.

Sign-ups will be on a first-come, first-served basis.

If you have signed up and need to cancel, please let us know. In the past, we have turned people away from overbooked classes only to end up with empty seats. This creates hard feelings all around and is rude. Please be considerate of your fellow union members.

Marshall Massie and I look forward to helping you all safely through this season.

Your Safety Department reminds you that one of the most serious risks you face is loss of your way of life, so don't forget to vote in the upcoming election, and remember to vote for your pocketbook and livelihood.

Until we see you in the classroom, work safely and drive defensively.

2004-2005 Hazmat Class Schedule

Location	Eight-hour refresher	40-hour (Monday - Friday)
District 04 - Fairfield	Saturday, Dec. 11; Friday, Jan. 14	
District 10 - Rohnert Park	Friday, Jan. 21; Thursday, Feb. 17	
District 12 - Salt Lake City	Saturday, Feb. 26	Feb. 28 - March 4
District 20 - Alameda	Saturday, Dec. 18; Saturday, Jan. 8; Saturday, Jan. 22	Dec. 6 - Dec. 10
District 30 - Stockton	Friday, Nov. 19; Friday, Jan. 28	
District 40 - Eureka	Thursday, Feb. 3	
District 50 - Fresno	Saturday, Feb. 12	
District 60 - Yuba City	Thursday, Jan. 13	
District 70 - Redding	Thursday, Dec. 16	
District 80 - Sacramento	Saturday, Dec. 4	
District 90 - San Jose	Saturday, Jan. 15; Saturday, Jan. 29	Jan. 3 - Jan. 7
RMTC		Jan. 31 - Feb. 4

FROM SAN FRANCISCO

Congratulations, Apprentices of the Month



First-step Apprentice Bree Demings works for Kiewit's joint-venture on the Skyway portion of the Bay Bridge. This is the first time she has worked near water.



Fourth-step Apprentice Douglass Russell runs the Haakon crane barge for Kiewit on the Benicia Bridge project.

FROM ROHNERT PARK

District to activate CAT for city council recall election

We would like to thank everyone who attended our district picnic and made it a success. Good food and good times were shared by all.

According to Marshall Bankert, our dispatcher, there are only 53 A-list operators on the out-of-work list. He also said we are ahead of last year in the number of dispatches for the district.

Granite Construction is currently working on the Santa Rosa Creek Prince Memorial Greenway project. Dave Millerick is the project foreman. He has operators John Kvasnicka and Brian Thomas working on the project.

North Bay Construction is working on the Sewer Collection System in the city of Sonoma. Operators Louis Lovell, Manuel Rodríguez and Kevin Hawk are working on this year-long project. North Bay Construction is also working on the Montgomery High School athletic field improvements, a \$3.4 million project, and doing the site work for Santa Rosa Junior College's new library, a \$1.1 million project.

Argonaut Constructors has a project on Hwy. 20 in Lake County. John Bles Jr. is the foreman, and he has about six operators working on the project.

We are currently in negotiations with Nortrax West, our John Deere dealership, and Syar Industries of Healdsburg.

As far as politics, we are starting early in District 10. There is a recall election in the city of Rohnert Park

Aug. 24. The election is to recall two members of the city council, Amie Spradlin and Armando Flores, because they signed a memorandum of understanding with the Federated Indians of Graton Rancheria and its proposed casino outside the city limits of Rohnert Park. The MOU would provide \$200 million over the next 20 years to help mitigate some of the impacts of the casino. The tribe has fulfilled the first part of the MOU and gave the city \$700,000 for a gang task force. We are against the recall because we supported Spradlin and Flores in their elections to city council. If the opponents to the casino are successful with the recall and are able to reverse the MOU, there is no guarantee the tribe would find a new location for its

casino, and the city would lose \$200 million. We are also supporting the casino because the tribe has signed a project labor agreement with the Building Trades Council, so all jobs during construction will be union. The tribe has also agreed to negotiate with IHERE, the hotel workers' union, so once the casino is built, the jobs will be union. We will put the OE CAT into action for the recall election. We need your help on phone banks and precinct walking.

George Steffensen, our newest business representative, had the honor of going to Lake County and



Operators Brian Thomas (left) and John Kvasnicka (above) work for Granite Construction on the Santa Rosa Creek Prince Memorial Greenway project.



Retiree Paul Bertalla proudly displays his 50-year clock at his home in Lake County.

presenting Paul Bertalla his 50-year clock because he wasn't able to attend the Retiree Picnic at Rancho Murieta. Bertalla said he is proud of being a Local 3 member and is grateful for a wonderful retirement.

The Rohnert Park District office expresses its congratulations and best wishes to the following:

Clarence Wafford married Wendy in Ukiah Dec. 24, 2003. The happy couple resides in Redwood Valley.

Matt Matej married Bethanie Ogg June 19. They reside in Santa Rosa.

Congratulations to Pedro and Esmeralda Hernandez on the June 7 birth of their boy at Sutter Community Hospital. Bryan Vigil Hernandez was welcomed home by his sister, Eileen. The family resides in Santa Rosa.

District picnic a big hit



From left: California Assemblywoman Pat Wiggins, retired District Rep. Joe Tarin, President Bob Miller and Rec. Corres. Secretary Rob Wise display Tarin's Commendation from the California Legislature.



FROM YUBA CITY

Summer work picture hot in District 60

There is plenty of work in District 60 this summer. Terracon Pipeline is working on Butte House Road in Yuba City. The \$4.2 million job will consist of 20,000 feet of water pipeline originating from Yuba City. The Tierra Buena Waterline project, as it is called, started June 7, and the termination date is Nov. 1.

Stimpel-Wiebelhaus and Viking Construction are working on the Oroville-

Quincy Highway project, a realignment of Hwy. 162 out of Oroville in Butte County. The contract is for \$6.9 million. ATA Surveying of Roseburg, Ore., did most of the surveying. Force Traffic Control from Eden, Calif., is doing the traffic control. Baldwin Construction from Marysville will begin paving Aug. 1. The Lake Madrone Crossing will be widened, as will other places along the road.

Teichert is still picking up work in District 60. The company has several large jobs moving right along. Jaeger has a small job in Live Oak. Baldwin has \$5 million in paving work, including the Oroville Airport, Butte College and West Eighth Street in Chico.

A special announcement from District 60: Congratulations to Roy and Alice Ledbetter of Browns Valley, Calif., who celebrated their 62nd anniversary May 14.

FROM SACRAMENTO

Members busy with loads of dirt work in Lincoln

Work on the hill is starting to move quite rapidly with Teichert moving most of the dirt at the North Star Ski Resort and several subdivisions, one at Auburn-Folsom Road in New Castle and others in Roseville and Lincoln.

Kiewit and Ford Construction are also moving dirt in the Lincoln area.

R&L Brosamer and Granite Construction have part of the I-80 job for \$33 million, and Teichert has part of the same job for \$40 million.

Steve Manning Construction is working on the new pump station near the old Auburn Dam site. The station will feed water to the Lincoln area.

Steve P. Rados and Tidelands Construction are still working on the same pipeline jobs in Lincoln.

RJ Miles, Chevreaux Aggregates and other plants in the area are moving a lot of material.

Caltrans is busy doing its summer road repair and storm drain repair while the unions have been busy negotiating a contract with the state.

District picnic great fun for everyone

It was a near perfect summer day at our district picnic this year at Elk Grove Rotary Park. Unlike the scorching heat wave we experienced last year, a light breeze kept everyone in good spirits. Members and retirees enjoyed visiting with Business Manager John Bonilla, Vice President Frank Herrera, Treasurer Russ Burns and U.S. Congressional candidate Gabe Castillo. The kids had a great time playing games and jumping in the jump house. Thanks to all who came out.



A potato-sack race contestant takes one last leap before switching places with his relay teammate.



Gabe Castillo (standing at left) talks to Local 3 members and retirees about his bid for a seat in the U.S. House of Representatives.



Treasurer Russ Burns enjoys a conversation with Office Systems and Procedures Director Toni Mendes and 10-year member Al Perez.



Thirty-year member JR Bagley enjoys some time in the shade with his wife, Betty.



Vice President Frank Herrera and Yuba City District Rep. Dan Mostats share a few words with a District 80 member before lunch is served.



Amber Francis, daughter of Local 3 member Scott Francis, gets her nails colored by Vicki Marshall at the face-painting station.



Business Manager John Bonilla serves a generous helping of tri-tip to a member.

FROM FAIRFIELD

Crane and pipeline jobs pick up the work pace

ARB is doing 70 miles of 20-inch pipeline for Kinder Morgan. The line will run from Contra Costa County to Sacramento. As of mid-June, ARB has 100 operators on the payroll with more being added as the project progresses and permits are granted. Guida Surveying is working on the project as a subcontractor with 10 to 12 surveyors. The project should keep many of our brothers and sisters busy for at least six months. The Fairfield District would like to thank Local 3 member Charles Lambert for being our steward on this job; he's doing a great job monitoring our work and enforcing the contract.

Kiewit Pacific is still working on the new Benicia Bridge with subcontractors Malcolm

Drilling, Condon-Johnson and CC Myers. Ranger Pipeline has a storm drain job in Benicia that will last about a year. OC Jones & Sons and MCM are still on the Hwy. 37 and Hwy. 29 job in Vallejo. DeSilva Gates and Mountain Cascade are busy on a housing project in American Canyon. CC Myers and Shasta Constructors have bridge jobs in Napa, and R&L Brosamer has almost completed the Hwy. 29 wine train undercrossing.

The crane barns are keeping most of their steady hands busy. Refinery work is picking up. Haskell Corporation and Harder Mechanical are at Conoco Phillips in Rodeo with Bigge Crane & Rigging, Carone & Company and Hillside Drilling.

Maxim Crane Works will start a turnaround in September at the Tesoro Refinery in Martinez. Bigge will also be at Tesoro and at Chevron in September.

Morrow Equipment will begin erecting seven to 10 tower cranes at the Benicia Bridge in mid-August.

Dutra Dredging is busy with work at the levee break in Stockton, the San Rafael Quarry, and the Suisun and Oakland projects. Manson has most of its rigs working on the new Bay Bridge and the Benicia Bridge.

Ross Island Sand & Gravel is dredging in Isleton. Great Lakes Dredge & Dock will be in Richmond in late July and moving to Oakland when it's done in Richmond.

FROM FRESNO

Work picture in District 50 holding steady

The Fresno District continues to run smoothly. Work in the Fresno area is holding steady despite a slowdown on state public works projects. The private sector work, federal projects, and city and county budgets keep many Operating Engineers busy. Hopefully the state economy will be looking better so next year we will enjoy more freeway jobs.

Work in Madera County is going well. Two school jobs are in progress on the west side. Emmett's Excavation is moving dirt while Harris Plumbing and Mechanical does the underground work. On the east side of Hwy. 99, AC Paving and Bill Nelson General Engineering have the dirt work and underground work.

The private subdivision market is going crazy in Merced County, with dirt flying all around. W. Jaxon Baker and Royal Electric are performing runway improvements on Castle Air Force Base.

Working together is what unions are all about, and that is exactly what the brothers and sisters of Local 3 have been doing for member James Kirk, who was recently injured on the job. Bobbie Mack Grinding sponsored a benefit dinner for James on June 5. We thank Jerry Mack and all other contractors involved for organizing such a successful gathering for a great cause.



The Smooth Operators softball team played its first season earlier this year. Back row, from left: Coach Gus McClain and Randy DeSantiago. Front row, from left: Tabby Berstler, Lisa Livaudais, Kathy Tarango-Smith, Mike Shelley and Ken Smith.



Foreman Fred Telford (far left) and part of Teichert's crew on a subdivision job in Merced. Teichert will move about 600,000 yards of dirt in the first project phase.

the district office and request a voter registration form. We are grateful for everyone's support this political season.

The Fresno District is grateful for new Business Rep. Gerald Searle, an eight-year Local 3 member. For the past two years he has worked in the Organizing Department, covering northern California, northern Nevada and wherever he was needed. Searle knows several District 50 members from serving as an organizer, so when asked to serve as a business representative, he was pleased to have the opportunity to work with District 50 members again. Searle recently moved to Tulare with his wife, Michelle, and children, Austin and Samantha. District 50 members know Searle is helpful and supportive, and they do

not hesitate to contact him when they need a helping hand.

District 50 asks for volunteers next spring to participate in the Smooth Operators co-ed softball team. The team played its first season earlier this year, with a record of ... oh, what does it matter what their record was? The main thing is that they had fun! According to Coach Gus McClain, the team established a unique style of play on the field. If you would like to participate in a few weeks of fun next April, contact the district office. Supporting fans are always welcome.

Congratulations to Julie and Dustin Stoops on the birth of their son, Timber. He was born June 16 at 1:04 p.m., weighing in at 8 pounds, 15 ounces and measuring 20.5 inches long.

We look forward to seeing everyone at the Fresno District meeting Thursday, Aug. 5 at Cedar Lanes in Fresno.

Fresno District staff serving you!

Ras Stark, district representative
Ray Ronell, assistant district representative
Sam Uhler, business representative
Gerald Searle, business representative
Denise Alejo, dispatcher
Kathy Tarango-Smith, member services



2004 picnic schedule

Stockton, CA	Sunday, Aug. 1
San Jose, CA	Sunday, Aug. 15
Fairfield, CA	Monday, Sept. 6

August Picnic Information

District 90 – San Jose, CA

Date: Sunday, Aug. 15
Time: 10 a.m. to 4 p.m.
Location: Christmas Hill Park, 7050 Miller Ave., Gilroy, CA
Cost: Adults and children older than 10 years - \$10 early bird or \$12 at the door. No charge for children under 10 years old and retirees.
Menu: Tri-tip, chicken, hot dogs, salad, beans, garlic bread, ice cream, beer and soda.
 Tons of raffle prizes and entertainment for the kids!

District 30 – Stockton, CA

Date: Sunday, Aug. 1
Time: 11 a.m. to 4 p.m.
Location: Micke Grove Park, 11793 N. Micke Grove Road, Lodi, CA
 **\$5 admission charge at gate (per car)
Cost: Adults and children older than 12 years - \$10; Retirees - \$8; No charge for children younger than 12 years.
Menu: Steak, hot dogs, beans, salad, French bread, corn on the cob, ice cream and free beer and sodas.
 Come enjoy raffle prizes, a horseshoe contest and a jump house and clown for the kids.

September Picnic Information

District 04 – Fairfield

Date: Monday, Sept. 6
Time: 11 a.m.
Location: Peña Adobe Park in Vacaville
Cost: Adults - \$8; No charge for retirees and children younger than 12 years.
Menu: Tri-tip, hot dogs, salad, beans and drinks.
 Enjoy great raffle prizes, jumper for kids and live music!

2004 Academic Scholarship Winners



Business Manager John Bonilla, Oakland Mayor Jerry Brown, Oakland Mayoral Candidate Ignacio De La Fuente and Brian Morton of the Thomas Morton Foundation stand proudly with Local 3's first- and second-place scholarship winners and their families after the award ceremony July 18 in Alameda.



Business Manager John Bonilla congratulates Ashik Manandhar, son of Local 3 member Gautam Manandhar, after he received \$3,000 for the first-place scholarship award.



La'Donnike Ford won second place in Local 3's academic scholarship contest and on July 18 accepted a \$2,000 scholarship from Brian Morton of the Thomas Morton Foundation, the sponsoring organization. Local 3 member Warren Ford was there to watch his daughter receive the award.

Random-draw scholarship winners

Danielle Bellew Madera, CA Parent: Michael Bellew Reg#: 1761415	Jacob Honesto Morgan Hill, CA Parent: Edward Honesto Reg#: 1710884	Kaylan Sheehy Mt. Shasta, CA Parent: Dean Sheehy Reg#: 2335331
Gregory Bruce Gerber, CA Parent: Ronald Bruce Reg#: 2118458	Elain Lawler Vallejo, CA Parent: Bradley Stringfellow Reg#: 1586409	Samantha Sheppard Fremont, CA Parent: Larry Sheppard Reg#: 2491538
Kimberly Bush West Sacramento, CA Parent: Mark Bush Reg#: 2162545	Ashley McMullen St. Helena, CA Parent: Raymond McMullen Reg#: 1904060	Joshua Streeter Selma, OR Parent: Sabrena Rosenberg Reg#: 2077424
Kristine Clifford West Valley City, UT Parent: Steve Clifford Reg#: 2018171	Larson McNeil Concord, CA Parents: Ian & Anne McNeil Reg#: 1842971 & 1963710	Jaime Swain Concord, CA Parent: Patrick Swain Reg#: 2136127
Amber Cornelius Minden, NV Parent: Robert Cornelius Reg#: 2026986	Amy Morris Oakley, CA Parent: Alan Morris Reg#: 1980796	Kira Waters Willits, CA Parent: Wayne Waters Reg#: 2158053
Christine Douglas Wellington, NV Parent: Michael Douglas Reg#: 2135932	Jared Noble Pioneer, CA Parent: Joel Noble Reg#: 2198166	Lourena Yeo Aiea, HI Parent: Louie Yeo Reg#: 2407968
Cammy Fumar Columbia, CA Parent: Ronald Fumar Reg#: 2091388	Jordan Pendergrass Napa, CA Parent: Clint Pendergrass Reg#: 1842555	

DISTRICT MEETINGS**AUGUST 2004**

- 5th** District 50: Fresno, CA
Cedar Lanes
3131 N. Cedar
- 12th** District 12: Salt Lake City, UT*
IBEW Local 354
3400 West 2100 South
- 19th** District 01: Burlingame, CA
Machinists Hall
1511 Rollins Road
- 26th** District 11: Reno, NV
Engineers Building
1290 Corporate Blvd.

SEPTEMBER 2004

- 2nd** District 20: Oakland, CA
Warehouse Union Local 6
99 Hegenberger Road
- 2nd** District 10: Rohnert Park, CA
Engineers Building
6225 State Farm Drive
- 9th** District 90: San Jose, CA
Masonic Hall
2500 Masonic Drive
- 14th** District 17: Honolulu, HI
Washington Inter. School Cafeteria
1633 So. King St.
- 15th** District 17: Kona, HI
King Kamehameha
Kona Beach Hotel
75-5660 Palani Road
- 16th** District 17: Maui, HI
Maui Beach Hotel
170 Kaahumanu Ave.

OCTOBER 2004

- 7th** District 12: Ogden, UT
Marriott Hotel
247 24th St.
- 7th** District 30: Stockton, CA
Italian Athletic Club
3514 Cherryland Drive
- 14th** District 04: Fairfield, CA
Engineers Building
2540 N. Watney Way
- 21st** District 80: West Sacramento, CA
ILWU Hall
600 4th St.
- 21st** District 01: Novato, CA
Inn of Marin
250 Entrada
- 26th** District 40: Eureka, CA
Red Lion Inn
1929 4th St.
- 27th** District 70: Redding, CA
Engineers Building
20308 Engineers Lane
- 28th** District 60: Yuba City, CA
Sutter-Yuba Board of Realtors
1558 Starr Drive

* Location change

Retiree Association Meetings**OAKLAND**

Tuesday, Aug. 31 10 a.m.
Oakland Zoo - Snow Building
9777 Golf Links Road
Oakland, CA

CONCORD

Wednesday, Sept. 1 10 a.m.
Centre Concord
5298 Clayton Road
Concord, CA

UKIAH

Thursday, Sept. 2 10 a.m.
Discovery Inn
1340 N. State St.
Ukiah, CA

ROHNERT PARK

Thursday, Sept. 2 2 p.m.
Operating Engineers Building
6225 State Farm Drive #100
Rohnert Park, CA

WATSONVILLE

Thursday, Sept. 9 10 a.m.
VFW Post 1716
1960 Freedom Blvd.
Freedom, CA

SAN JOSE

Thursday, Sept. 9 2 p.m.
Masonic Temple
2500 Masonic Drive
San Jose, CA

**Hawaii
Pre-Retirement
Meetings**

Planning for your retirement is important. Your Local 3 retirement benefits will generally comprise a major portion of your retirement income. We encourage you and your spouse to attend this meeting and familiarize yourselves with all aspects of your retirement benefits. These benefits have a direct bearing on your financial security and deserve your attention. All meetings begin at 6 p.m.

HONOLULU

Tuesday, Sept. 14
Washington Intermediate School Cafeteria
1633 So. King St.
Honolulu, HI

KONA

Wednesday, Sept. 15
King Kamehameha Kona Beach Hotel
75-5660 Palani Road
Kailua-Kona, HI

MAUI

Thursday, Sept. 16
Maui Beach Hotel
170 Kahumanu Ave.
Kahului, HI

SEMI-ANNUAL MEETING

Rec. Corres. Secretary Robert L. Wise has announced that the next Semi-Annual meeting of the membership is Sunday, Sept. 26 at 1 p.m. at the following location:

Sacramento Convention Center
1421 K St.
Sacramento, CA

HONORARY MEMBERS

The following retirees have 35 or more years of membership in Local 3 as of June 2004 and are eligible for Honorary Membership effective July 1, 2004.

Scott Allen	0982895
Frank Alvarez	0865493
Larry Edgcombe	1069163
Henry Gonsalves	1382362
Peter Gonsalves	1296056
Cecil Johnson	1276872
Billy M. Knauff	1425292
Robert Leslie	1382398
William Parrott	0283805
Myron Pederson	1382885
Frank Picardo	1219675
Ernest Prater	1364970
Rickmer Riewerts	1022333
Thomas Rodriguez	1076518
Jesse Via	1235251
Thomas Westoby	1382486

Reminder: membership card

Rec. Corres. Secretary Robert L. Wise reminds you to carry your current Local 3 membership card as proof of your good standing and identification as a member of Local 3. Having a current card with you allows you to participate and vote at meetings.

Star-Spangled Search



Local 3 member Dwayne Wright sings a heartfelt rendition of the national anthem at the March 14 Semi-Annual meeting.

Oh, say, can you sing the National Anthem? If so, Local 3 needs you!

This summer, for the first time ever, Local 3 is sponsoring a unionwide singing contest – it's a "Star-Spangled Search" for any member with vocal talent who is interested in singing the national anthem at the next Semi-Annual meeting in Sacramento. VHS tape-recorded auditions are being accepted by Local 3's Public Relations Department now through Aug. 30. Please submit your audition tape, along with your name and

telephone number, to:

Operating Engineers Local Union No. 3
Public Relations Department
Attn: Star-Spangled Search
3920 Lennane Drive
Sacramento, CA 95834

Please note: The winning Star-Spangled Search contestant will be notified by phone the first week of September. S/he will be responsible for all travel expenses associated with the trip to Sacramento for the Sept. 26 Semi-Annual meeting.

Around town



Back to school

Business Manager John Bonilla recently sat in on some apprenticeship classes at Rancho Murieta. After class, the apprentices posed for a picture with Bonilla, RMTC instructors, apprenticeship coordinators and staff.

Operating Engineers Local 3 welcomes the following new contractors

- | | |
|--|--|
| CL Service Company
District 04 - Fairfield | Frank's Backhoe Inc.
District 60 - Yuba City |
| Mr. Crane Inc.
District 04 - Fairfield | Custom Crushing Industries
District 70 - Redding |
| Minix Excavators
District 04 - Fairfield | Dronkanoki Inc./West Coast
Consulting Construction Services
District 80 - Sacramento |
| E.A.C. Electric
District 10 - Rohnert Park | Aspen Development Corp
District 80 - Sacramento |
| B & R Mobile Rock Crushing
Services
District 10 - Rohnert Park | California Waterscape
District 90 - San Jose |
| Big J Construction
District 20 - Oakland | NBSCO Inc.
District 11- Reno |
| Sprader & Company
District 20 - Oakland | JD's Sweeping & Rentals
District 11- Reno |
| B.J. Rees Enterprise
District 50 - Fresno | RDK Construction
District 11- Reno |

Departed Members

Our condolences to the family and friends of the following departed members:

Alberto, Joseph Tillamook, OR 05-19-04	Greenwood, James Eureka, CA 05-18-04	Orig, A. Honolulu, HI 05-25-04
Alexander, Hollis Yuma, AZ 05-18-04	Hipp, Buster Chinese Camp, CA 05-31-04	Pulliam, Roy Kearns, UT 05-26-04
Arakawa, Thomas Kaneohe, HI 05-18-04	Killion, James Reedsport, OR 05-26-04	Robinson, Michael Milpitas, CA 04-27-04
Bailey, Eugene Sacramento, CA 05-09-04	Lambert, Jim Oakdale, CA 06-04-04	Sasser, Everett Hopland, CA 05-25-04
Baker, Jay Reno, NV 05-11-04	Martinez Sr., Charles Reno, NV 05-19-04	Sharp, Don Palo Alto, CA 05-29-04
Britton, Arthur Fresno, CA 02-16-04	Maurer, Ken Groveland, CA 05-18-04	Tye, Ben Belen, NM 05-29-04
Butts, Kriby Sanger, CA 05-23-04	Mefford, Jack Redding, CA 05-10-04	Williams, Douglas Salida, CA 05-20-04
Fee, Gary San Ramon, CA 03-24-04	Montgomery, Reldon Corning, CA 05-02-04	Wilson, Fred Stockton, CA 06-01-04
Gray, Albert Napa, CA 06-01-04	Newell, Larry Dobbins, CA 04-18-04	Yarnell, Michael Oakley, CA 05-02-04

Deceased Dependents

Miller, Verna, Wife of Miller, Noah	05-01-04
Adams, Delores, Wife of Adams, Teddy (Dec)	04-12-04
Aldredge, Louise, Wife of Aldredge, Albert (Dec)	02-18-04
Anderson, Marie, Wife of Anderson, Alton	04-27-00
Chapman, Jeanette, Wife of Chapman, Howard (Dec)	05-06-04
Haynes, Nancy, Ex-wife of Harrell, Rick	06-02-04
Newell, Patrick, Son of Newell, Mike	06-19-04
Ogden, Marcia, Wife of Ogden, Jack	04-24-04
Tryon, Mamie, Wife of Tryon, W. (Dec)	04-19-04
Winton, Mary, Wife of Winton, Leroy (Dec)	01-16-04
Withers, Freda, Wife of Withers, Harold (Dec)	04-30-04

SwapShop ads are offered free of charge to members in good standing for the sale or trade of personal items and/or real estate, and are usually published for two months. Please notify the office immediately if your item has been sold. Business related offerings are not eligible for inclusion in **SwapShop**. *Engineers News* reserves the right to edit ads. No phone-in ads please. Deadline 1st of the month. Limit two ads per issue.

To place an ad, type or print legibly and mail to:

**Operating Engineers
Local Union #3
3920 Lennane Dr.,
Sacramento, CA 95834
ATTN: SwapShop***

**Or fax ads to: SwapShop
(916) 419-3487**

**Or e-mail to:
webmaster@oe3.org**

*All ads must include Member Registration Number or ad will not appear. Ads should be no longer than 50 words.

FOR SALE: 2000 36ft Tahoe 5th wheel, 3 slide outs. In great shape, never traveled in! 22k/obo. 916-789-1775. Reg. #270279

FOR SALE: 1996 Alpenlite 36ft 5th wheel trailer. 2 slideouts, awning, central air and heat, new 15,000btu air conditioner. Built in microwave, refrigerator, entertainment center, tv, vcr, stereo w/cd. Excellent condition. Glass door closets in bedroom, oak wood cabinets. Lots of storage. \$26,000/obo. 925-686-5017 or 925-383-1881. Reg. #225929

FOR SALE: 1968 Buick 430 motor. All complete motor, trans, carb, starter, etc. \$1,000. 925-685-1389. Reg. #1136381

FOR SALE: Two burial lots, vaults and marker in veterans section in Fresno Memorial Gardens. 208-682-3507. Reg. #0969094

FOR SALE: Property in Willow Creek Estates, Amador County. Approximately 6ac, 3bd/3ba, central a/c and heat, ceiling fans, wood stove, 3 stall barn, RV parking, work shop, 30x40 garage, apartment or mother-in-law quarters, 2bd/1ba, too many amenities to list. 209-245-3532. Reg. #1812603

FOR SALE: 12ft aluminum boat, truck tool box, twin box spring & mattress, all baby items, fire truck toddler bed, dinnet set, 5 man tent (Wentzel), exercise equipment. 209-245-3532. Reg. #1812603

FOR SALE: 4 tires like new P225/60 R16. 408-266-1058. Reg. #835689

FOR SALE: Flat bed dump 8'x8' steel bed, Sherman brand \$1,000. 1972 Dodge 1ton no bed \$500 or trade. TD9 transmission free. 530-346-2918 or e-mail farmerj@cwnet.com. Reg. #1271053

FOR SALE: AMC 390 CID engine bored 30 over less than 5000 miles since rebuilt and balanced all papers. Can be had with fuel injection or 4BBL Holly. \$1,500/obo. Tohatsu outboard 5hp motor long shaft like new with cart and gas can. \$500. 650-494-2009. Reg. #1242916

FOR SALE: '72 Commando convertible hard top 304 eng. Auto tranny and power steering, power buster and new seats. Needs some work. Runs good. \$4,500/obo or trade for a motorcycle or a boat. This car is in Fresno. Call after 5:00 p.m. or leave a message at 559-252-1372. Reg. #2443714

FOR SALE: Two burial lots in Oakmont Memorial Park in Lafayette, CA. Call Earl or Erma at 209-823-8416. Reg. #1181671

FOR SALE: Like new! 2001 National Seaview 31ft Class A motorhome, wide body, basement model, 25k miles, slides, Ford V-10, generator, back-up camera, jacks, a/c, awning, slide covers, tow package, queen bed, two tvs, tub/shower, microwave, convection oven, extended warranty, negotiable resort membership. \$64,995. 916-207-3803. Reg. #1265340

FOR SALE: 1995 Terry 29.5 5th wheel trailer. Electric and gas water heater, microwave, 18ft awning, 28amp Onen generator completely self-contained. Direct tv, satellite antenna. \$8,000. 916-361-8333. Reg. #1447143

FOR SALE: The Mayan Palace Resorts Vacation Club Suite, one week and additional two weeks per year in a 2bd/1ba suite at the Vidafel/Sea Garden Mazatlan Resort, Vacation ownership give you access to the golf course with a minimum of 20% discount off green fees and cart rental. Motivated seller, make an offer or call for more information. 650-712-1733 or fax 650-712-1778 or e-mail CIMDonna@aol.com. Reg. #2149166

FOR SALE: Safari Ranger Scooter with oxygen tank holder and front basket. \$1,800. Like new. Also Pride Power Wheelchair used twice. \$1,900. 408-683-4376. Reg. #0707267

FOR SALE: Meade EDT-90EC Astro Telescope with tripod and electronic controller. Recently upgraded and realigned. Accessories include electronic focuser, Canon ring, 64 camera adapter, 8x25 range finder, EZ finder reflex, carrybag. \$950 value, sell \$550. Grass Valley 530-477-8837 any time. Reg. #0865600

FOR SALE: Dodge motorhome, 318 cubic inch engine. Very low mileage and good tires and a very good unit. Doesn't have to be smogged each year. Yours for only \$1,895 cash. Located in Redding, CA. 530-243-4302 after 6:00 p.m. Reg. #0865537

FOR SALE: Family farm with 2 houses (1 rented) 27 miles NW of Eugene, OR in scenic valley. 44+ acres, year-round creek, pasture hills, 20 year old trees, barn, shop, bunkhouse, walnut grove. \$349,500. Motivated seller. 541-925-4137. Reg. #1494208

FOR SALE: Koehring horizontal jack and boring machine with 12" to 24" casing and 120ft of augers. Used very little and ready for work. \$9,500. 707-664-1784. Reg. #1047032

FOR SALE: Texoma model 600 foundation drill. 25ft drilling depth, auxiliary hoisting winch, 610 hours on drill, mounted on all wheel drive fwd truck with 45,000 miles. Unit is ready for work and asking a bargain price of \$49,000. Will consider backhoe trade. 707-664-1784. Reg. #1047032

FOR SALE: 2003 Skyline Layton scout model M276 w/slide. Has power jack, scissor stabilizer, 15,000btu a/c, microwave, sleep 6, am/fm cd cassette stereo with surround sound, luggage rack with ladder, skylight in bathroom, cabinet upgrade with protect and carpet also has protectant. Lots of storage. Too many amenities to list. Willing to sacrifice for \$25,000/obo. Owner must sell. 707-678-2071 or 707-678-3185. Reg. #2268774

FOR SALE: 1999 F250XLT crew cab gold six speed 7.3 liter diesel, bed liner overload springs, excellent condition, miles 128,935. Owner must sell. Asking \$17,500. 707-678-2071 or 707-678-3185. Reg. #2268774

FOR SALE: 1986 Chevy 3/4 T 4x4 Suburban 350 V8 at, loaded, all options, 2nd owner. 86k original miles, very good original condition. Must sell. Best offer. 510-381-6995. Reg. #1624253

FOR SALE: 1997 FL60 Freightliner 3126 Catipiller, 6

speed, Allison, air ride, 150 gal. fuel tanks, exhaust break, many extras. 51k miles. All custom to tow large 5th wheel/horse trailer. 707-446-7975. Reg. #0661383

FOR SALE: 2003 GMC Envoy pewter, low miles - 13,500. Asking \$27,000/obo. Warranty. Custom running boards and Billet grill. 559-269-3416 or e-mail mvera@oefcu.org. Reg. #2489223

FOR SALE: 1978 Dodge Jamboree Rallye motorhome. 18ft Class C with 84k miles. 360 motor, smogged and tagged until 3/05. Self-contained. Two almost new tires. \$2,000. 559-292-2641 or 559-779-2559. Reg. #1312793

WANTED: Case 580 Super E Buckets, any size. Also interested in Aux. Hydraulic set-up and dangle drill for same. Looking for ripper bar too. Case/Furgie/Gannon or other 4 to 6 foot. 510-794-8768. Reg. #1832925

FOR SALE: 2002 BMW K1200 LTC silver, showroom condition. 4,500 miles. 5 speed w/OD and rev. gear, ABS custom luggage rack, heated seat and grips, power windshield, rear trunk with speakers, 6yr ext. warranty. Paid \$25,000. Divorce, must sell for \$15,200/obo. 530-758-3212. Reg. #1793823

WANTED: Austin Healey 1953 to 1960 models 100m, 100.4 and 100-6. Also looking for old antiques General Jumbo's Wheels any bolt pattern in 15" or 16" diameter. 510-223-9040. Reg. #1305660

FOR SALE: Factory Safety Cab with mounting brackets, heavy duty for Catapillar, like new. \$1,250/obo. 1928-29 Case Tractor, runs. Ford 9N needs work. \$3,500/obo for both. Tandem boat trailer for 15 to 20ft boat. \$500. 1992 Chevy V8 Caprice, good condition. 110,000 miles. \$3,600. Rowe Jukebox good condition with records. \$800. 916-911-1530. Reg. #486196

FOR SALE: Shoulder machine. Will base and pane 6" to 40" wide. Can be used to base and pane trenches. 559-732-7828. Reg. #1058404

FOR SALE: Flat dump bed 8'x8' heavy duty Sherman brand \$1,000. D4 track rails 36 links 6" pitch \$400. Rebuilt starter Detroit 92 Series \$100. 1972 Dodge 1 ton \$500 or trade. TD9 transmission for free. 530-346-2918 or farmerj@cwnet.com. Reg. #1271053

FOR SALE: Country living in good area. 3bd/2ba, family

room with fireplace, sunroom with 8' Marquis Spa, approximately 2,000sq.ft; short of an acre, room for recreational vehicles. Great view. In Oroville, CA. 4 miles from lake. Asking \$315,500. 530-589-0694. Reg. #233968

FOR SALE: 2003 YZ450F Yamaha. Low hours, stock bars, grips, tires, seat, plastic, Faultline suspension front and rear, Stealhy 16oz Flywheel weight, FMF Q exhaust passed Hollister sound check, kick-it kickstand, CR style brake line, X-ring chain, 51 T rear sprocket. \$4,950/obo. 530-472-3237. Reg. #1181781

FOR SALE: 25 acres Northern Arizona heavily treed. 3bd/2ba, large front porch, 34ft covered flagstone patio, root cellar, complete solar system, pond, water garden, 8ft waterfall, new sod, fruit trees, flowers, 8 hole golf course with underground sprinklers. Large garden spot, fenced 100gpm 1240' deep well, washer & dryer, side-by-side fridge, propane furnace and cook stove, wood stove will heat the house. Off the grid!! \$260,000. 928-899-8466. Reg. #2241844

FOR SALE: 2000 Suzuki JR50 like new \$850. 1973 16ft Thunderbird tri-hull boat with a 50hp outboard engine. \$1,200. 916-485-2433. Reg. #2342396

FOR SALE: 4.6 acres in Northern California adjacent to Eureka. Southern exposure. Established young tree farm, mature fire wood and lumber trees. Buy the land and partially finished house a gift. Winter 40 degrees, 70 degrees hot summer day. Large shop building with over head crane. \$500,000. 707-725-5323 or 707-443-7783. Reg. #1487929

FOR SALE: 1997 Mercury Cougar, red/grey leather, sharp, excellent condition. 68,000 miles. \$6,850. 530-365-7879 or 515-963-8043. Reg. #0529093

FOR SALE: 1988 Chevrolet Silverado K2500 4x4. Newer dark blue metallic paint, 63k miles on dealer installed 350 cu.in. engine, rebuilt TH400 automatic transmission, Tow package, Flowmaster exhaust, Alpine am/fm CD stereo, A/C, sliding rear window, lots of new GM parts, all records and receipts. \$5,500/obo. 925-449-0858. Reg. #1820687

FROM UTAH

Politicians enjoy breakfast picnic with District 12

This year's picnic was held May 22 at a new location – Draper Park. About 320 retirees, actives and families attended the breakfast. Several activities were planned for adults and children, but the favorite was exchanging stories about one another on the job.

Our members were fortunate to hear from Local 3 President **Bob Miller** and several prominent politicians and candidates, including U.S. Rep. **Jim Matheson** from Utah's Second Congressional District; his brother, gubernatorial candidate **Scott Matheson**; state Rep. **David Ure** and state Sen. **Ed Mayne**.

The picnic concluded with a raffle after which members continued to revive old friendships before leaving the park.



Retiree **Lynn Reese** (far right) and District 12 members visit with President **Bob Miller** at the May 22 picnic.



From left: President **Bob Miller**, 50-year members **Lewis Peterson**, **Rex Gray**, **William Payne**, **John Suazo** and District Rep. **Jim Sullivan**.



Business Rep. **Kit Morgan** serves breakfast to gubernatorial candidate **Scott Matheson** (in line, at left); his wife and campaign manager, **Robyn Matheson**; Retiree and former dispatcher, **Murray Stevens**; and his wife, **Penny Stevens**.

FROM HAWAII

Entertainers and ono eats make for great picnic

Warm waters, a pristine beach and swaying palms provided the idyllic setting for a most successful picnic for members on the island of Oahu. The event was Saturday, June 12 at Campbell Estates' private grounds in the Ko Olina Resort.

Dignitaries attending the picnic included Business Manager **John Bonilla**, President **Bob Miller** and Financial Secretary **Harold K. Lewis**. We were pleased to also have Organizing Director and Fresno District Rep. **Ras Stark**, Political and Public Relations Director **Cindy Tuttle**, **John Sweeney** of ATPA and Fringe Benefits Director **Charlie Warren** in attendance. Legislators present included state



Sens. **Cal Kawamoto** and **Brian**

for their help with the event that from all indications was our best picnic ever. We're already planning for next year.

Kanno and mayoral candidate **Mufi Hannemann**.

The entertainment was definitely the hit of the day. Well-known local entertainers **Brother Noland**, **Darren Benitez** and **Friends**, and the wildly popular comedy group, "Da Braddahs," performed. Some hidden talent was discovered in the karaoke contest from participants **Clyde Paling**, **Vee Rohr**, **Mike Satele** and **Nina Kahoonei-Leedy**. Seventy-five raffle prizes were given away.

Hats off to the Local 3 staff, Stabilization Fund, Multi-services, Hawaii JAC and OE CAT members



Above: A pristine beach and warm waters provided an idyllic setting for the District 17 picnic June 12. At right: Families and friends enjoy the festivities and ono (delicious) eats.



Financial Secretary **Harold K. Lewis** and Business Manager **John Bonilla** in good spirits at the district picnic.



About 600 members and friends enjoyed ono huli huli chicken, rice, hot dogs, hamburgers, macaroni salad, watermelon and ice cream.

FROM EUREKA

Members asked to get involved, support project funding

John N. Petersen Company began work on the water treatment plant in Hoopa and should employ five to seven operators through October. The company is also actively bidding other work, and we will keep you posted.

Mercer Fraser packed up one of its hot plants and moved it to Callahan for the federal highway job it picked up there. It will be working on the project for the rest of the season. The company is also working on the Fairway Drive culvert replacement in Eureka and will keep three to four operators busy through October. Mercer Fraser's rock, sand and gravel plants are working in Fortuna, Trinidad and Dinsmore.

Granite Construction picked up work on Samoa Road and Hwy. 255

— and the Arcata and Crescent City plants are running.

Shasta Constructors was the apparent low bidder for two highway projects in Del Norte County, and we are all waiting for the notice to proceed, which is dependent upon funding.

Wahlund Construction has all but finished a pipeline job for the city of Eureka. Ken Wahlund is aggressively bidding more work in the area.

Funding is becoming a large stumbling block here as it is across our jurisdiction, which shows us how important it is to be active in district activities. Go to your district meetings, get active in the CAT and be there for each other. Together, we can accomplish great things.

We are still waiting for the state to sit down with us and negotiate the Unit 12 contract. As soon as a budget gets approved, we expect to see some movement. Let's all support our brothers and sisters at Caltrans. Give them a honk, and wave when you see them out there on our highways.

We are currently preparing for negotiations with the cities of Arcata and Eureka for the great Local 3 units we have in those communities. Speaking of public employees, Business Rep. Tina Love is moving forward with the North Coast Air Quality employees, who initiated a recognition petition with 100 percent participation. Stay tuned on this one; hopefully we will get a contract quickly.

Doe's Mobile Service signed an agreement to train apprentices. John Antongiovanni went out there and did a great job for them — he showed what a great job Local 3 does training our apprentices. When non-union employers sign these agreements and our apprentices go out and do a job, it goes along way in getting them signed to the master agreement. Great job, John!

We recently signed KWR Services, a Eureka-based paving, demolition and vector service company, to the master agreement. District 40 welcomes Ken Reynolds and his crew to the Local 3 family.

Have a safe season, and thanks for the support.

FROM RENO

An enjoyable district picnic for members, friends

More than 400 friends and family members enjoyed great food, conversation and entertainment at the Reno District picnic. It was a very enjoyable day. Reno staff would like to thank the CAT members who volunteered to help us set up early Saturday morning and the many volunteers who helped throughout the day. Many thanks to Member Doug Kight for cooking his delicious beans, Member Buzz McHaney for the entertainment, OE CAT Coordinator Theresa Reclusado for organizing the Ride to Reno and the riders who participated. Thanks also to the many employers and vendors that contributed gifts for our raffle.

We were honored to have several elected officials come to the picnic and visit with Local 3 members, including state Rep. Bernie Anderson, Reno Mayor Bob Cashell, Reno City Councilwoman Sharon Zadra, School Board members Dan Carne and Galen "Mitch" Mitchell and Washoe County Commissioner Pete Sferrazza.

It was a great privilege to award our 50-year members with their watches and clocks. District Rep. Chuck Billings thanks President Bob Miller, Vice President Frank Herrera and Treasurer Russ Burns and our members for supporting the Reno picnic. Thanks to the Reno staff for their hard work.



ment at the Reno District picnic. It was a very enjoyable day. Reno staff would like to thank the CAT members who volunteered to help us set up early Saturday morning and the many vol-



From left: Leonard Mathews, Vice President Frank Herrera, President Bob Miller, District Rep. Chuck Billings, Ron Hoover, Robert Boyer, Bob Yturiaga and Treasurer Russ Burns.



In the rodeo spirit, members enjoy each other's company.



Flutter-By entertained kids with face painting and balloon sculptures. Here, she makes a butterfly for Montana Fullerton.



Above: Reno riders enroute to the District 11 picnic.

At right: Dan and Marsha McCowan relax after lunch.



Members Lee Webb (left) and Justin Gantt have their blood pressure checked by Michael Johnson (center), a Local 3 health care provider from Nevada.



The 4th Annual Ride to Reno crew.